

113

October
1984

elektor

INDIA

Rs. 7.50

electronics

NEW

THE BASIC PRINCIPLE

tachometer • SCART adapter • flash meter •
electronic cross-over filter •
anodizing aluminium •
lamp economizer •
news • views •
people •



**data communication
by telephone**

elektor INDIA kits

are now
available
from :

precious[®]

List of kits currently available

EPS No.	Title	Price Rs.
EPS 78003	Power Flasher.	85.00
EPS 80543	The Stamp.	57.00
EPS 83113	Video Amplifier.	115.00
EPS 83088	Electronic Voltage Regulator.	130.00
EPS 83098	Battery Eliminator.	90.00
EPS 83508	Volt-Monitor.	40.00
EPS 83503	Signal Injector.	50.00
EPS 83597	Egg Timer.	55.00

General Information:

1. The price includes packing and postage.
2. Maharashtra Sales Tax will be added extra. Please add 15% when making remittance.
3. All despatches will be by Regd. Post.
4. Please send full amount by D.D. or M.O. No cheques or V.P.P.
5. Allow 3 weeks for despatches.
6. The kits contain the PCB and components that go onto the PCB.

precious[®]
ELECTRONICS CORPORATION

Chhotani Building, 52C, Proctor Road
Grant Road (East), Bombay-400 007
Phones: 367459, 369478

More kits will be introduced soon.

1. Elektor India brings you the very latest in electronic techniques.
2. These new techniques are presented in a simple easy-to-understand style.
3. Elektor India offers something to interest every reader, be he beginner or expert.
4. Thanks to Elektor India's ready made PCBs, construction is made simpler than ever.
5. Last year Elektor India brought you the most advanced ideas from all fields of electronics (audio, microprocessor, instruments, etc.)
6. This year will usher in a whole new range of test equipment, the BASIC principle, real time analyser and more.
7. In August/September of each year, we publish our famous **circuits special issue**, containing over 100 different circuits.
8. Elektor India publishes over 250 circuits every year.
9. Elektor India is the simplest way to keep up-to date with the rapidly changing world of electronics.
10. Thousands of satisfied readers testify to the popularity of Elektor India, roughly 50% of all letters we receive name Elektor India as the best electronics magazine in India.

10

GOOD REASONS FOR SUBSCRIBING TO

elektor INDIA electronics

MONTHLY MAGAZINE
Use the order card in this issue.

SUBSCRIBE NOW

contents

news — views — people	10.14
selektor	10.16
Scene of science: a look at the Science Museum in London.	
data communication by telephone	10.18
Linking your computer to the telephone network is the 'in' thing for 1984: what happens between two communicating computers is described in this article.	
active cross-over filter	10.22
A versatile active network which provides far better audio frequency transfer than most passive filters.	
digital cassette recorder with the ZX 81	10.29
As promised earlier here is the solution to the problems which have prevented our digital cassette recorder from being used satisfactorily with the ZX 81.	
flash meter	10.30
Essentially a light meter, this unit is intended as an aid to achieving the right flash under all conditions: a 'must' for the serious amateur photographer.	
digital tachometer	10.35
To many drivers a tachometer is more important than the speedometer: yet, most car manufacturers fail to provide one. Here's your chance to make good that regrettable omission.	
DIRPUT	10.40
We offer a couple of new instructions for the Junior Computer with the Ohio Scientific disk operating system.	
SCART adapter	10.42
A new plug-and-socket connection between a television receiver and associated equipment such as a video recorder or teletext decoder is becoming a European standard.	
anodizing aluminium	10.46
An alternative means to paint-spraying for the protection of aluminium cases and panels.	
lamp saver	10.48
A unit which is easily added to existing installations to increase the life of incandescent light bulbs.	
double-sided printed circuit boards	10.52
Ways and means of making your own through-plated printed circuit boards.	
applicator	10.54
A new memory IC from Mostek that is compatible with both the CMOS RAM 6116 and the 2716 EPROM.	
telephone amplifier	10.56
The circuit described will pick up the telephone conversation and reproduce it via a loudspeaker, so that several people can listen in.	
market	10.59
switchboard	10.67
missing link	10.74
index of advertisers	10.74



The front cover illustrates a direct-coupled data circuit terminating equipment (DCE), popularly called a modem (contraction of modulator / demodulator) and a telephone: the two essential units for linking a computer to the telephone network. In this issue we describe what happens between transmitting and receiving computers that are linked by a telephone line. Next month we offer you the opportunity of building your own modem.

Part one of the series on the "BASIC PRINCIPLE" is featured in this issue. The remaining three parts will be published in our future issues.

Quintus



Test & Measuring
Instruments

PHILIPS

The way ahead in microcomputer development

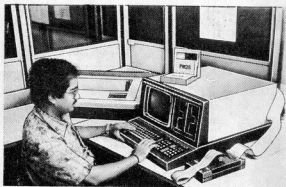

Philips PM 4422, the new generation development system that gives your designers the essential tools for getting your latest microprocessor based projects out from labs to production fast. Lower costs, less labour intensive to give you that vital competitive edge.

The secure investment
PM 4422, the latest advance in Philips Microcomputer Development Systems (PMDS) series — following established PMDS concepts of upgradability, full hard-

ware and software compatibility. PM 4422 goes further — it can be extended from a highly cost-effective single-user system to a powerful multi-user system of upto 7 work stations! So PM 4422 grows with your development program.

Massive hard-disk storage
A built in 5¼" Winchester drive gives a standard capacity 5 or 21 Mb. Add on extension units allow on-line storage expansion to 147 Mb. Internal memory 1 Mb. from 256 Kb to

UNIX⁺-based OS

PM 4422 has powerful UNIX⁺-based OS supporting multi-user, multi-task environments. Making it easy to generate complex programs by joining simple, easy-to-understand modules — a big contribution to transparency of users software, making debugging simpler and faster.

Supports latest technologies

Wide support facilities for both 8-bit and 16-bit devices with full real-time emulation at true operating speeds.

Full field upgradability

Existing PMDS users can field-upgrade to the latest specifications to benefit from the advanced PM 4422 — proving again the value of the PMDS full upgradability principle.

For more information on Philips PM 4422 and PMDS, please contact to:

Philips India
Test & Measuring
Equipment Division
Plot 80, Bhosari Ind. Estate
Pune 411 026

*Trademark of BELL Laboratories

CBM/1865

Philips — the trusted Indian household name for over fifty years

**HM
307**

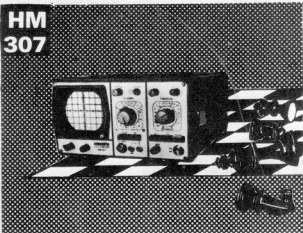

307 KNOCKS OFF ALL COMPETITION

scientific HM 307 winner of WIS|TEX '81 **First Prize** and still the only portable scope with a **single touch** component tester.



Capacitor 33 uF Transistor E-C Transistor B-E BE 1 uF + 68 ohms

Specifications :

- Bandwidth (-3 db): 10 MHz
(-6 db): 15 MHz
- Fast 35nS risetime
- Sensitivity: 5mV—20V/cm
- Auto or variable trigger upto 30 MHz
- Built-in component tester
- Excellent layout for quick troubleshooting
- Lightweight, only 4.5 kg

some products are so good that you don't have to boast about them

scientific

SCIENTIFIC INSTRUMENTS (INDORE) PVT. LTD.

B-14, Industrial Estate, INDORE 462 003 Ph: 31777
Telex: 0735-267 Customer Services at: Bombay
Bangalore, Calcutta, Delhi, Hyderabad, Madras

<p>Sub Miniature Slide Switch 0.3A. 30V.</p>	<p>DIP Extractor</p>	<p>Insulating Spacers</p>
<p>Socket Adapters & Covers</p>	<p>Swivel Stand Offs For PC Boards</p>	
<p>Insulating 'L' Brackets</p>	<p>Snap In Fixing Indicating Lamp</p>	<p>Dial Clamp</p>
<p>Insulating Bush</p>		

INSTRUMENT CONTROL DEVICES
14, Rukmini Niwas, Ashok Nagar Road,
Datar Colony, Bhandup (E), Bombay-400 078 (INDIA)

Padhye Ar

FLASH 82-8

the NAME for Power Devices

HEAT SINK

Pressure-Die-Cast for
STUD • PRESS-PUK • EPOXY DEVICES

Selenium/Silicon Rectifiers/Diodes Thyristors

Assemblies/Stacks KH-RIR-USHA Electronic Components.

the LIFE LINE for Semiconductors

CONTACT **ELECTRONICS AND INDUSTRIAL ANCILLARIES**
252, Raja Garden, New Delhi - 110 015 Phone : 505524
DOMINION RADIOS
15, New Queens Road, Opera House, Bombay - 400 004.
Phones : 350747, 382 968. CABLE "DOMIRA"

Extruded for HOCKEY PUK (Compression) Devices Assemblies • Hardware



If born in the twentieth century even Beethoven would have been amazed by our rendition of the 9th Symphony. Born less than a year ago our performance has already become a Magnum Opus.

Dyanora, Ahuja Radios, Uptron, Niky Tasha, Philips—rather a top heavy customer list? Isn't it! Our intention was to topple the market. We've done it! Our speakers have found their way into the most sophisticated Televisions and Audio Equipment of the country. In the field of audio installations too, our credibility is vouched for by The Plenary Hall and Committee Room at the Vigyan Bhawan, Pizza King Restaurants, and a host of others.

An enviable list of customers to inspire us to greater heights of performance, precision, development with the by now famous Intertec quality & reliability

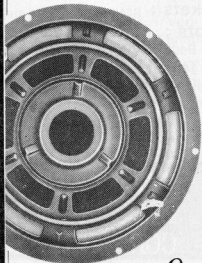

i **INTERTEC**

Intertec Audio Products Division

Intertec Fabricators & Engineers Pvt. Ltd.

A- 36, Sector X Noida Distt. Ghaziabad, (U.P.) India.

Telephone: 635714, 632191 Telex: 031-5217 JUNA IN

Cable: JUCHAGENCY

Our Speakers—Speak for themselves.

LATEST FROM APLAB

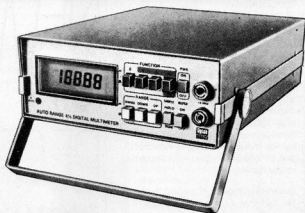

Aplab's new autoranging 4½ DMM model 1085S ensures precision measurements economically.

Automatic selection of ranges of AC/DC voltages, currents and resistances.

It is a versatile multimeter with high resolution, accuracy and reliability. Easy to use. A must in repair or maintenance shops, research, design and development laboratories.

AVAILABLE EX-STOCK

Features:

- ★ AUTORANGING
- ★ HIGH ACCURACY
- ★ HIGH RESOLUTION: 10µV ON 200 mV RANGE
- ★ 10M HIGH INPUT IMPEDANCE
- ★ 4½ DIGIT, 11mm HIGH LCD DISPLAY
- ★ OVERRANGE INDICATION WITH BEEPS AND BLINKERS
- ★ AUTOZERO AND AUTO POLARITY
- ★ SAMPLE HOLD FACILITY
- ★ MAINS CUM BATTERY OPERATED
- ★ DIODE TEST FACILITY

Applied Electronics Limited

- Aplab House, A-5 Wagle Industrial Estate, Thane 400 604.
Phone: 591861 (3 lines), Telex: 011-71979 APEL IN.
- Nos. 44 & 45 Residency Road, Bangalore 560 025.
Phone: 578977, Telex: 0845-8125 APLB IN.
- 8/A Gandhi Nagar, Secunderabad 500 003. Phone: 73351.
- 22C, Manohar Pukur Road, Calcutta 700 029.
- MF-3 Stutee Building, Bank Street, Karol Bagh, New Delhi 110 005.
Phone: 578842, Telex: 031-5133 APLB IN.

Aplab—Leadership through technology

Hail Electronics :

Electronics, the harbinger of a new technological revolution, sometimes meets with resistance from a misinformed section of the people who condemn any modernisation, fearing that it will cut into the existing job opportunities.

A recent survey has thrown fresh light on the potential of electronics industry which is not well known even among the policy makers.

An investment of about Rs. 1 crore in the field of electronics can create an estimated 312 jobs while the same outlay in chemical industry will provide only 33 jobs. Similar investment in ferrous products and automobile and bicycle industries can give work for 66 and 91 people, respectively, according to the survey.

Electronics industry can also boast of the fact that it consumes meagre electricity and the capital required is comparatively less. The fixed assets for creating a job in electronics has been calculated to be around Rs. 32,000 while in other industries, the assets should be at least four times more.

The importance of electronics industry has not been realised a day too early and the envisaged investment of Rs. 500 crore by the government in this sector is welcome decision. The electronics production target for 1990 in India has been set at Rs. 10,000 crores when the world production would have crossed Rs. 74,000 crores. To achieve the 1990 target, an investment of about Rs. 2,000 crores is needed in India, according to experts. A strong production base for the indigenous manufacture of components and policies such as elimination of the burdensome indirect taxes on electronics will accelerate the growth of this industry at a faster rate.

The Electronics Component Industries Association (ELCINA) has urged the government to prepare an integrated fiscal and import policy package to overcome the difficulties caused by continuous changes in the import policy. Rationalisation of the customs duty structure and introduction of freight subsidy to step up export of electronic components are among the other suggestions made by the ELCINA to the government.

Computer Shops

Computer shops, which have the "flavour" of a coffee shop, will be set up soon in the country. All the requirements of computer users, irrespective of the type of computers and the brands used, are expected to be available under one roof.



Full computer systems, peripherals like floppies, disc drives, printers, special computer furniture, software package, airconditioning systems, computer stationery and books can be obtained from this shop. The new company, called "Computer Point", is said to be modelling its project after the Computerland chain concept of the USA.

The computer shops, with their beginning in Bombay will be set up before the end of this year in other cities like Bangalore, Hyderabad, Delhi, Madras and Calcutta.

While manufacturers can use these shops as an assured outlet for their new products, computer users too have an advantage. They will have opportunities for comparing different models in one place and the various claims made by the manufacturers of different systems can be easily verified. This is not possible under the existing market conditions where the consumer is flooded with a barrage of offers, drowning him in confusion and delaying the decision.

Meanwhile, the government has exuded optimism in declaring that computer prices are likely to fall further as competition is growing among the newly licensed manufacturers. Over 140 units have been approved for the manufacture of computers including the mini-computers and microprocessor-based systems. As the technology for producing large computers is not available in the country, the department of electronics has floated global tenders for the purchase of the know-how. The Electronics Corporation of India Limited will undertake the pro-

duction programme. Though initially the ECIL will take up this job, depending on the demand, others may also be allowed to produce large computers.

Advisory Panel

A 25-member advisory council for electronics industry has been set up by the government of India. Representatives from the industry, the planning commission and various ministries have been included as members.

The council, apart from serving as a mediating agency between the government and the industry in solving mutual problems, will help in the formulation of the seventh five-year plan for the industry, according to Mr. S.R. Vijayaker, secretary to the department of electronics.

Import of electronic components may be further curtailed during the seventh plan period. Steps are likely to be taken to limit the import of components to 10 per cent from the existing level of 25 per cent.

The government has also expressly recognised the reluctance on the part of foreign countries to sell the know-how as India planned one-time import of technology, to be backed by indigenous R & D.

The secretary also dispelled the fear that the department was imposing certain technologies on anyone. He defined centralisation of technology as a means to standardising components and facilitating large-scale production and it did not mean limited production. This clarification comes in the wake of reports that the proposed centralised purchase of technologies by the department of electronics might hamper the private sectors' enthusiasm in the manufacture of telecommunication equipment, which has been thrown open to them recently.

Struggling hard to enforce quality control on the colour television sets produced by the private sector in the country, the department of electronics has threatened to cancel the supply of colour TV tubes to those manufacturers who do not fulfill the "limited quality test". The department has already diluted its test control by switching over to 48-hour-laboratory test called limited quality test from the 1,000-hour working of the set in the lab under the "comprehensive quality test".

Medical Electronics

Production of medical electronic equipment, a much-neglected area, has caught the attention of the planners and the seventh plan envisages a production target of Rs. 350 crores.

The target appears to be a tall order as, in 1982, production of medical electronic equipment in the country hardly exceeded Rs. 13 crores and in 1984, it may touch Rs. 20 crores. The estimated demand this year is put at Rs. 45 crores.

The requirement of medical electronic equipment in 1985-86 is expected to be around Rs. 76 crores and the indigenous production is likely to be about Rs. 30 crores.

The department of science and technology has estimated that a tentative investment of Rs. 60 crores has to be made to achieve the seventh plan target. More than all this, local manufacturers have to be given some "protection" against the liberal import of these equipment through the ever-expanding list of "life saving devices" and the import policy has to be suitably amended, it is felt.



Sunil Gavaskar Launches 'Diamond'

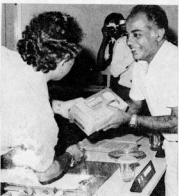

... and hands it over to the distributor

M/s. Plastart introduced their four New Products — 'DIAMOND' Desolder Pump & SUPER-81 T.V. Antenna Booster with unbreakable PVC moulded body, VHF to UHF T.V. Channel converter and stand off insulators for T.V. Antenna Booster

mounting that ensures loss-free gain. Well Known Cricketer Sunil Gavaskar launched these four products at a jam-packed function held on 25th August 1984, at Maratha Chamber of Commerce Hall, PUNE. Shri P.S. Deodhar, Chairman — E.T. & T.D.C. Government of India, presided over the function.

M/s. Plastart are a constituent of the well-known 'Vaidya' group of Industries of Pune and have been in electronics field for many years now, with genuine quality products to their credit.



Shri P.S. Deodhar Inaugurates 'Precious' Office

On the 9th of August 1984 Shri P.S. Deodhar, Chairman E.T. & T.D.C., Government of India, inaugurated the new office of Precious Electronics Corporation and Elektor Electronics Pvt. Ltd., at Chotani Building, 52-C Proctor Road, Bombay 400 007. By taking this step, 'PRECIOUS' are now geared to give even better service to their valued patrons. The facilities now offered at the new office include a large counter for component sales.

A separate counter has been provided for Students, Hobbyists & Technocrats where the magazine, kits, PCBs and data books are available. Precious is a well known marketing house in electronic components in India and abroad with backing of over two decades of experience. In 1983 they entered the field of publishing through their associates M/s. Elektor Electronics Pvt. Ltd., to bring out magazine and books on electronics with a view to bring the latest, on the international scene, to Indian readers, at a very low cost.

Electronic typewriters from Godrej

For the first time in the country, Godrej and Boyce Manufacturing Co. Ltd. has introduced a fully indigenous electronic typewriter.

The know-how for the new typewriter, which is marketed in three models, was developed by the company with the assistance of the Indian Institute of Technology, Bombay.

The basic model (Model-1) has several features like erasing centering, carriage movement, margin setting, tabulation and half spacing - all operated automatically. Model No. 2 has an additional facility of built-in memory to store and print out texts. The third model has a further facility of visual display to enable the user to scan and modify the text before typing directly or from the memory.

According to Mr. S. P. Godrej, the Chairman of the company, the prices of the three models placed at the lowest level range from Rs. 19,995 to Rs. 31,995 inclusive of all taxes. Accessories like ribbons, eraser, tapes and printwheels will also be supplied by the company.

Order has been received for 100 units and good demand is expected for the new machine. The Company is planning to manufacture about 8000 typewriters in the next two years.



Scene of science

London's Science Museum is different from most museums. It is, as stated in one of its brochures for visitors, a crowded and friendly place. "It is not a place where people stand in silence before objects they feel they should, and possibly do, admire, and move quietly, as in a church. It is somewhere where people feel free, and often excited; where they talk loudly (sometimes *too* loudly) and even laugh." What is not widely known is just how much highly-skilled work goes on behind the scenes to maintain a constantly-changing panorama of science past, present—and future.

London's Science Museum leads all others as a tourist attraction. Visitors in 1981 were some four million, twice as many as visited the Tower of London or St Paul's Cathedral. Its only world rival is the Deutsches Museum in Munich, and it can be said that the Science Museum has the biggest collection of science and technology in the world. There are certainly other well-known museums but not one that specializes entirely in science.

Its method of management has been changed recently. Up to now it has been financed by the UK Department of Education and Science, with administration wholly the responsibility of the Director, Dame Margaret Weston, and her staff. This is to change, to bring the museum into line with others, and the administration will be in the hands of trustees appointed by the Prime Minister. Whether this will produce any significant change in policy remains to be seen.

Another aspect of the Science Museum's activities underlines how widespread its reputation now is in Britain. This is the appearance of outstations in several parts of the country. The latest of these — the National Museum of Photography, Film and Television — was opened in Bradford, an industrial town in northern England earlier this year. It has one of the largest cinema screens in Britain and the very latest in film projection systems, called IMAX. The first film to be shown was an award-winning history of flying. The theatre also has a multiscreen slide show controlled by computers. Such use of the most advanced

techniques shows how much we must revise our notions about what we call a museum. It need not be only a collection of 'old' material; the Science Museum is right up-to-date and looks into the future, too.

There is also an exhibition at the Fleet Air Arm Museum in Somerset, where one can see the first British-made *Concorde*. Yet a third outstation is the National Railway Museum at York, the famous cathedral city in the North-East. All of this suggests that the Science Museum is more than its name implies; it is a national institution.

It is situated in what might well be dubbed museumtown, a large part of West London that includes the Victoria and Albert Museum, the Geological Museum and the famous Natural History Museum. The area covers about 120 000 square metres. We can ignore all the involved history — it has been enthusiastically recorded by Sir David Follett* — and say that the Science Museum as we know it really began with the appointment of Colonel Henry Lyons as Director in 1920. By 1933 when he retired he had, as Follett wrote,

"developed the Museum into one of the foremost technical museums in the world." By 1928 the first new building was ready for opening by King George V, and has been growing ever since.

But why have a science museum? Indeed, what purpose does a museum of any sort serve? There were none until a very few centuries ago, and even those were more collections of curiosities culled by world travellers and victorious generals than a museum as we now understand it. (The Ashmolean Museum at Oxford, which celebrated its tercentenary last year, started in a similar way.)

New Culture

The people of earlier times were vandals: famous buildings almost disappeared to serve ambitious thieves, or crumbled from philistine neglect. It was not until the Renaissance was well under way that people became interested in the story of national culture, first of all in artistic and cultural artefacts. Then, in the late 18th century, Britain opened the first campaigns of the Industrial Revolution, which grew rapidly in the 19th

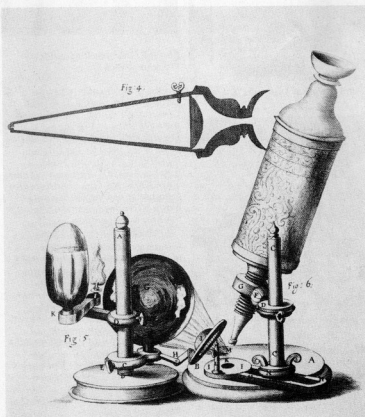

Hooke's Compound Microscope (Photograph from Hooke's *Micrographia* (1665))

century. Science and technology became challenging new aspects of culture, and with them came a growing interest in earlier science.

These developments made people reflect on the aims and functions of a museum. First, there was preservation. Machines and apparatus would disappear like old toys unless they were carefully preserved. Sometimes machines endure and are in a very dilapidated condition; then it is the task of the Museum's special staff of metal workers and cabinet makers, with the help of whatever old drawings may still be available, to reconstruct and present them in their original state. The originals of many devices no longer exist or are not accessible, in which case the craftsmen build models to scale, often travelling far afield to look at surviving pieces. New materials and adhesives are studied to keep the technical side up-to-date.

Another task is education, which involves presentation. Objects in museums devoted to artistic pursuits speak for themselves and need little more than a name, but in a science museum this is not so. The purpose of a piece of apparatus and how it works must be explained in some detail.

Finally, there is the job of entertaining. It would be of very little use to bunch exhibits together in an unorganized way. Furthermore, things with moving parts may have switches or other means of making them work at the wish of a visitor. This is done at the Science Museum to a great degree; there is even a Children's Gallery where young people may do their best to test devices to destruction without ever succeeding.

Every scheme imaginable is used at the Science Museum to make presentation entertaining. There are pictorial techniques, for example the diorama of mediaeval agriculture painted by a well-known artist. There are working models, such as a computer with print-out and visual display unit against which a visitor may try his skill. There are life-size models of settings with sculptured men or women, as shown with the 18th century wooden printing press and a surgery of 1900, with a doctor measuring a patient's blood pressure. One can see a steel-maker at work on the open-hearth furnace; careful use of colour and light gives a very convincing picture of red-hot steel. This technique is even more impressive when displaying a red-hot ingot of iron: one feels afraid to touch it.

Continuous tapes looped into recorders give a running commentary on processes nearby. There are life-size models of space-exploring satellites and in the Children's Gallery there is, among many other things of course, a periscope of the kind used in a submarine, which can be operated by any visitor.

There is a life-size model of a pharmacy of 1905 with two customers and one pharmacist, representing a time when many a chemist made his own pills. There is a reconstructed ship's bridge. One could go on for a long time selecting fascinating items that show the display skills of the 50-strong team of craftsmen, many of them artists, working in the well-equipped workshops of the Museum. Educationally the Museum is unequalled. There can surely be no better method of teaching, say, physics than by taking pupils to the Science Museum. They can learn a great deal about microscopes, for example, by looking at exhibits that range from Læwenhoek's device and Hooke's to the most modern instruments for optical or electronic magnification.

More can be learned in an hour than by many hours in a classroom. And it is not all old material. The *Apollo 10* spacecraft is there, with a full-size copy of the *Apollo 11* lunar 'lander' module and a one-sixth scale model of *Surveyor*; there is also a full-size model of the *Sputnik*. To encourage pupils in an educational way, many leaflets on various subjects are available with questionnaires which the pupil can answer on the spot and at home.

The Museum acquires its exhibits in several ways. Some are given. Some are bought privately or by bidding at auction. Others are on permanent loan. One famous addition is the Wellcome Museum of the History of Medicine, which covers such matters as the story of antiseptics, anaesthetics, scientific aids for doctors, and the eradication of smallpox in every part of the world.

For good presentation the exhibits must be organized into families or groups such as motive power, iron and steel, agriculture, sailing ships, magnetism and electricity, space exploration and rocketry, structure of matter, meteorology, locks and fastening, photography, atomic physics and nuclear power, computing and so on.

Special Exhibitions

Among the crowded galleries on five floors, space is provided for special exhibitions. Some of them are open for only a few weeks or months,

after which they may be taken round Britain. Last year there was an enormous special exhibition, *Telecommunications*, marking the centenary of Standard Telephones and Cables (STC). It showed everything from line telegraphy to radio and satellites, and optical fibres (the world's first telephone link by this means was opened by the UK Post Office, now British Telecom, in 1977). Very little was left out in this fascinating story, from Oersted's work on electric current through to the first primitive telegraphy, followed by the earliest transatlantic cable, the coming of radio, the thermionic valve, then the transistor, electronic telephone exchanges, subscriber trunk dialling (STD), the use of lasers with optical fibres, and so on.

Among the wealth of material there are many 'firsts' or near-firsts. There is, for example, the world's earliest surviving steam locomotive, *Puffing Billy* of 1813. There is the first locomotive to pull a passenger train, Stephenson's *Rocket* of 1829. The visitor can see the world's earliest photographic negative (by Fox Talbot, the founder of photography as we know it).

In basic physics there is J.J. Thomson's apparatus with which he 'discovered' the electron in 1897. There is also C.T.R. Wilson's cloud chamber, with which for the first time the tracks of atomic particles could be seen, work that speeded up the study of the structure of matter probably by a decade at least. There are very early motor-cars, including a Rolls-Royce *Silver Ghost* of 1909. (Incidentally, though the primary interest is science, many early exhibits are aesthetically interesting and many, indeed, beautiful: see early telephone receivers or sewing machines, for example, elegant in brass scrollwork.) But this is old history and in a way contributes to the notion that museums are stuffy. Science and technology, however, are developing disciplines. What is new today will be old tomorrow. In this respect the Science Museum is up-to-date and even projects into the future: nuclear fusion, as a source of power, is not yet proven, and there are huge machines still experimental; nevertheless there is a display covering the technology.

**The Rise of the Science Museum under Henry Lyons, by David Follett, 1978.*

In the last few years the telephone network, which was originally intended for voice communication, is being used more and more for transmitting (digital) data. The growth in the popularity of home computers has been startling but it is not really surprising that their users should seek to use the telephone lines as a medium for exchanging programs and data. What happens between transmitting computer and receiving computer is, however, still a mystery to many people so we felt that it was time to clarify this. Also included in this article is a description of the AM 7910, which is a commonly used dedicated modem IC.

data transmission by telephone

how do two computers 'converse' over the telephone lines?

When Alexander Graham Bell first had the brainwave that led to the development of telephone he would have found it difficult to envisage the idea of two computers using his system to communicate with each other. Cassette tape, which, again, was designed for storing audio 'information', has long been used for storing computer data, and in the same way the telephone line can perform a duty other than allowing far-away friends to converse. There are certain limitations, of course, but using the telephone lines two computers can exchange messages, programs and data in digital form. It is of little interest for the purposes of this article to deal with the actual telephone network as what we are really concerned with is how data can be transmitted over telephone lines, what speeds are possible and what a modem does. As a start, however, we will talk about the telephone.

The telephone line

The normal telephone line, that runs into every subscriber's home, is what is known as a switched line. There are a number of switching points (mostly in the form of telephone exchanges) between any two subscribers. The frequency range of this

sort of line is from about 300 to 3400 Hz, which is quite sufficient for speech. This range limits the speed at which data can be transmitted to less than 2400 baud, however, as transmission rate is frequency-dependent. Another type of telephone line is the hire line, which has a higher quality. The maximum transmission rate on a normal hire line is 2400 baud, going up to 4800 baud for a local hire line and even 9600 baud on a high-quality hire line. Hire lines are not generally used by amateurs. Each end of the line is almost invariably connected to a telephone receiver. The basic principle of the telephone system (except for the dialling section) is outlined in figure 1. The actual connection is made via two wires, a and b. There is also an earth line present which our drawing does not show. The signal provided by the carbon microphone is superimposed on the d.c. voltage supplied from the exchange. At the other end the signal is extracted from the d.c. and causes the bell in the second telephone to ring. When the hand-piece is lifted from the hook the 'a' line is connected not to the bell but via a transformer to the earpiece, where the signal is reconverted to the original audio information (generally speech). We are not interested in any other circuitry in the exchange or the interconnecting line. We

Figure 1. In the normal (two-wire) telephone system the signals in both directions travel on the same line.

1

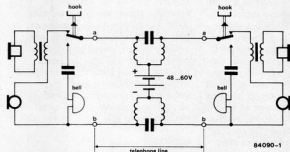

now know, in any case, that the signal is superimposed on a d.c. voltage and that the same lines carry information in both directions. This latter fact is particularly important as special measures are needed if both sides want to transmit data at the same time.

A modem at each end

The connection between computer (or terminal) and telephone line is made via a so-called modem (Modulator/DEModulator). Two basic types of modems exist: acoustically-coupled and direct-coupled. In the case of the first of these the information must be exchanged with the telephone handset via a microphone and a loudspeaker. The second type, as its name suggests, is connected directly to the telephone line. The direct-coupled modem is much less sensitive to noise and interference so there are less faults during data transmission but it must be designed very carefully so as not to produce interference itself. Both types of modem must have type approval.

The actual function of a modem is to convert serial digital information into an analogue signal that can be transmitted via the telephone line, and to receive and reconvert information from the line. To enable different modems to be connected to the same network a standard is required. The CCITT (Consultative Committee for International Telegraph and Telephone) makes various recommendations for the different transmission rates and types of line. The V24 standard applies for the link between computer and modem. The modem itself should keep to the V21 and V23 standards. These standards specify whether the modem uses synchronous or asynchronous transmission, what the data transmission rate is, what the procedure is for automatic call and answering, what tests should be carried out and whether there is a control (back) channel present. In short: they specify everything needed to enable two modems to communicate with each other on the same level.

The CCITT's V21 recommends a transmission rate of 300 baud in full-duplex mode over a two-wire connection (allowing simultaneous transmission and reception of data). V21 is used for all normal data transfer.

The V23 standard, on the other hand, recommends a dual-speed half-duplex transmission at a speed of 1200 and 75 baud. The 75 baud channel is then used for control purposes.

Bits in the telephone

Before the data can be transmitted via the analogue telephone line it must be coded. The modem does this by means of modulation. There are several different ways of doing this:

AM, in which the amplitude of the carrier signal changes with the logic level (see

2

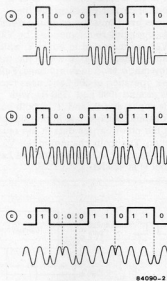

data transmission by telephone

Figure 2. Various different methods of modulation are used when data is being sent over an analogue line. Indicated here are: AM — amplitude modulation — (a), FSK — frequency shift keying — (b) and DPSK — differential phase shift keying — (c).

3

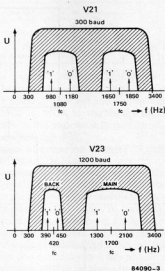

Figure 3. The carrier waves used in V21 mode (a) and V23 mode (b) must remain within the frequency range used by the telephone system.

figure 2a). The simplest form of AM is 'on/off keying' in which case the carrier is present for a '0' and not for a '1'.

FM, in which the simplest form, FSK (Frequency Shift Keying), is generally used. The two logic levels are represented by the carrier having two different possible frequencies. Data transfer over switched lines almost always uses FSK.

There are two more advanced techniques worth mentioning, namely DPSK (Differential Phase Shift Keying) and QAM (Quadrature Amplitude Modulation). The first of these uses phase shifting (figure 2c) and the second uses amplitude and phase shifting. Both of these techniques permit the data transfer rate to be

increased (relative to the others mentioned). All of these techniques use one or a number of carrier waves so the frequencies used must be carefully decided. The frequencies recommended by V21 and V23 are indicated in figure 3, which also shows their position within the frequency range used in telephones. Full-duplex operation at 300 baud uses two bands around 1080 and 1750 Hz, with 200 Hz separating '0' and '1' in both cases. One channel carries data in one direction while the other carries data in the reverse direction. The main channel in the V23 norm is centred at 1700 Hz, and the back channel is at 420 Hz.

That is all that needs to be said about the actual transmission via the telephone line. A modem is, however, required at each end of the line so we will now have a look at a modern modem contained in a single IC.

The AM7910, a single-chip modem

Virtually everything in this IC that could be digitalised has been digitalised. Even the filtering and generating the carrier (a sine wave) is done digitally. A block diagram of the complete IC is shown in figure 4. As could be expected, it contains

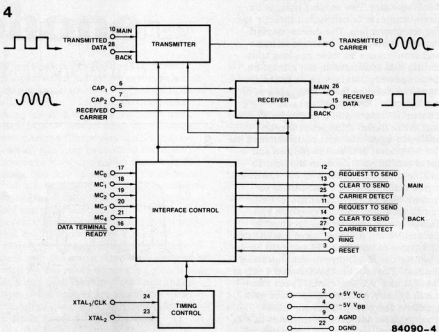

Figure 4. In the AM 7910 IC, whose block diagram is shown here, a complete modem is fitted on to a single chip. The signals are processed completely digitally.

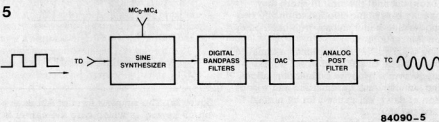

Figure 5. The transmitter section of the modem in slightly greater detail.

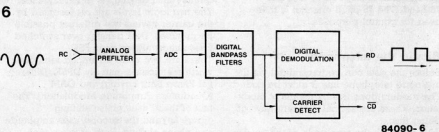
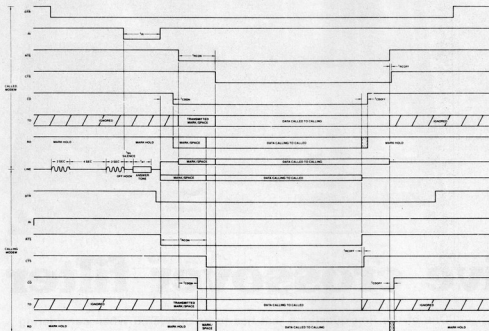

Figure 6. Here we see the various different subsections that make up the receiver section.



84090-7

a transmitter and a receiver, both of which are controlled by interface control and timing control sections.

Details of the transmitter are seen in figure 5. The serial data that are to be transmitted are fed in one side and leave from the other side as an FSK signal that can be sent over the telephone line. The FSK signals must be perfect sine waves in order not to clutter up the telephone lines. Sinewaves, at two different frequencies, are generated digitally and switching from one frequency to the other is only done when the signal is at its zero-crossing point. The digital FSK signal passes through a digital band-pass filter and is then fed via a digital to analogue converter to an analogue filter. All this filtering is needed to limit the amount of power fed onto the telephone line. This power must conform strictly to the regulations in order to reduce crosstalk and interference.

The modem's receiver section, shown in figure 6, reconverts the FSK signals to digital ones. The signal arriving over the telephone line is first fed to an analogue filter before passing to an analogue to digital converter with an exceptionally high-speed of 496 kHz (it needs to be fast because of the FSK frequencies). In this way the effects of the higher harmonics in the FSK signal are reduced. The final two stages are a digital band-pass filter and a digital demodulator after which only the data remains. A carrier detector indicates when there is data present.

All the 'traffic' between computer (or terminal) and modem is controlled by the interface control. This section has several inputs, MC0...MC4, to enable the modem to be set to the various different standards (such as V21 and V23).

The exact frequencies for the FSK traffic are generated by the timing control, which takes its reference from a crystal. The block diagram clearly indicates the lines for main and back channels. This is only needed for V23 (1200/75 baud) as V21 only makes use of the main channel.

An important feature of the IC is its auto-answer facility. This enables the modem to respond automatically to a telephone call. The communication protocol between computer and modem is very important and quite involved, as the timing diagram of figure 7 indicates. The example here shows the various signals and relationships for the AM 7910 when it is operating in V21 mode.

At first sight it may not be entirely obvious why a modem needs to be so complex. It soon becomes apparent, however, that all this complexity is, in fact, needed to ensure that data is transferred without any errors even when there is interference on the telephone line. It is also vital to prevent the modem from generating noise that could affect other telephone users. ■

Figure 7. The timing diagram for the modem (shown here in V21 mode) shows all the signals used and how they relate to each other.

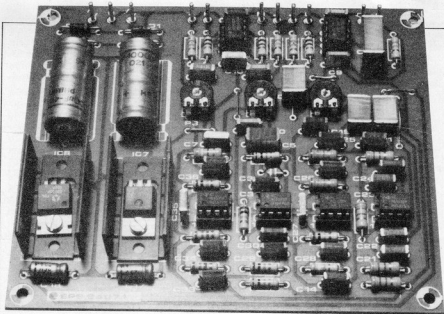

active crossover filter

One of the first questions that has to be answered when considering a new loudspeaker system is what sort of filters are to be used. Should it be a 'normal' passive design or is an electronic active filter what is needed? When the pros and cons are weighed up it will be obvious that, from a musical point of view, an active filter is preferable. When finances are taken into account, however, the passive system's lower price may prove to be the deciding factor. For the purposes of this article we will assume that finances take a back seat to faithful sound reproduction and simply concentrate on the design of this very versatile active crossover filter. We will, however, look at the differences between the two systems. The printed circuit board allows a choice between a two or three-way filter with a roll-off of 12, 18 or 24 dB per octave. It is also possible to use various different types of filter.

for active
loudspeaker
systems

In electronics we call a circuit 'active' if, along with the usual (passive) components like resistors, capacitors and inductors, it contains an amplifying element. It is obvious, therefore, what an active filter is, but the term 'active loudspeaker' may not seem so obvious. A loudspeaker, which really only consists of the cabinet and drive units (the actual loudspeakers), can, strictly speaking, only be passive, unless it has some mechanical feedback. In general, however, a loudspeaker equipped with an active crossover filter is called an active loudspeaker. This is partly due to the fact that power amplifiers are then often built into the loudspeaker cabinets. The differences between active and passive loudspeaker systems can be seen with the aid of the diagrams in figure 1a and figure 1b. In the passive system (figure 1a) the output signal from the preamplifier is passed through the power amplifier to the loudspeakers. A passive crossover filter, made up of coils and

capacitors, ensures that each of the drive units — woofer, mid-range and tweeter — is fed the appropriate part of the audio frequency range.

The active system, shown in figure 1b, operates slightly differently. An obvious difference is that the filtering is done earlier, directly after the preamplifier, in fact. The result of this is that the three filter outputs must each be followed by a power amplifier so that three of these are needed per channel instead of one. This makes the active system more expensive than a passive one.

Active or passive?

There is no definitive answer to the question 'Which is better, an active or passive loudspeaker system?'. The active system has more pros than cons but that does not necessarily mean that it is the right choice for everybody. Basically the active system is more complicated, bulkier, and more expensive than a passive version but

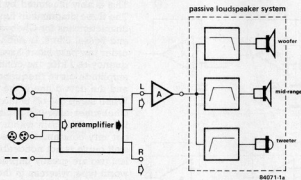

Figure 1a. In a passive loudspeaker system the crossover filter, made up of coils and capacitors, is located between the power amplifier and loudspeakers.

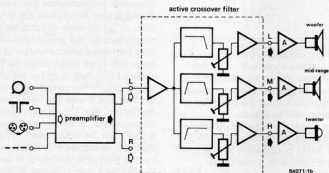

Figure 1b. The filter in an active system is placed directly after the preamplifier. Each drive unit then needs its own power amplifier.

these are the only drawbacks. That is not to say that the active system always sounds better. There are some passive loudspeakers whose sound cannot be faulted, just as there are some active systems that are very mediocre. In general, though, the active system is preferable. Its main advantages are:

- It is very easy to match different loudspeakers by amplifying the signal at one filter output or amplifier input. (This is also very accurate). With passive systems matching involves adding resistors for extra attenuation, which is fine for tweeter and mid-range but it will not work with a woofer (because it affects the damping factor). An alternative is to use a suitable transformer (which will be expensive) but this will mean that a woofer with a higher output than the mid-range and tweeter used can never be satisfactorily incorporated into a good three-way passive system.

- The loudspeakers are connected directly to the amplifier outputs (and not through big coils as in a passive set-up) so the damping of the loudspeakers is better. This results in more accurate reproduction, which is particularly marked in the bass range. This is probably the greatest plus point in an active loudspeaker system.

- The impedance curve of the loudspeaker in an active system does not affect the behaviour of the crossover filter so this always operates as it should. Consequently there is no need for any sort of

impedance-matching network.

- Without the numerous coils and capacitors used in a passive system the load seen by the power amplifier is less complex, which means that the sound reproduction is improved.

- The power amplifiers are located much closer to the actual loudspeakers (often within the loudspeaker cabinet) so the length of the loudspeaker cable is greatly reduced. This removes the need for special, expensive loudspeaker cable.

Basic circuits

Electronic crossover filters are actually quite easy to make nowadays, especially with the very good low-noise opamps that are available. It is a matter of choosing the correct characteristics and a practical layout. The actual filters can be chosen from a number of standard types. The basic circuits making up our crossover filter are shown in figure 2. Any sort of crossover filter can be made simply by combining a number of these circuits.

The upper two circuits (a and b) are low-pass filters; below them, c and d are high-pass filters. Circuits a and c each contain two RC sections and are therefore known as second-order filters. Their characteristic curve has a roll-off of 12 dB per octave (6 dB per RC section). Circuits b and d are first-order filters with a single RC section and a roll-off of 6 dB per octave. If a and b (or c and d) are placed one after the other the result is a third-order filter with a roll-

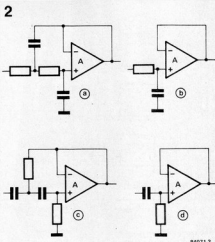

Figure 2. These are the basic circuits that will be used in our active crossover filter. The upper two (a and b) are low-pass filters while the other pair (c and d) are high-pass filters. The roll-off of the filter can be changed by combining these basic circuits.

off of 18 dB per octave. A pair of type a (or c) circuits in series form a 24 dB/octave fourth-order filter. When connecting filter sections in series the component values in the various sections must be carefully selected, as we will see later.

In figure 3 we see a comparison between three filter curves, of 12, 18 and 24 dB per octave. The filters in question have a low-pass characteristic with a cut-off frequency of 1 kHz.

The number of dBs of attenuation per octave that a filter provides is not the only important factor. For acoustic applications there are several other important criteria, such as the precise shape of the filter characteristic, the behaviour within the pass-band and the phase shift. Within certain limits these qualities can be changed by carefully choosing the filter components. This is very important as it means that the circuit does not have to be changed in order to have a different type of filter.

Three of the most common filters are the Chebyshev, Butterworth and Bessel types. None of these conforms to the 'ideal' filter characteristics of constant gain and linear phase shift (within the pass-band) very steep roll-off outside of the pass-band and negligible undesirable oscillation. All these characteristics cannot be combined in one filter so the right filter for any application is chosen by first deciding what is the most important feature.

Figure 3. The three curves here show the frequency characteristics of the 'same' filter for three different values of roll-off slope.

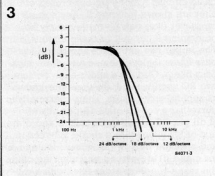

This is ably illustrated by figures 4 and 5. The three diagrams in figure 4 show the characteristics for Chebyshev, Butterworth and Bessel filters. In each case the fourth-order low-pass filters have a cut-off frequency of 1 kHz; the continuous line is the amplitude curve (frequency characteristic) and the dotted line is the phase shift.

When steep roll-off is most important the Chebyshev filter (4a) is clearly the favourite. The gain within the pass-band is not very constant, however, and the phase shift curve is not noticeably linear. These last two are greatly improved in the Butterworth type, whereas in the Bessel filter (c) a 'flatter' phase curve is achieved at the expense of a slightly less steep roll-off.

The most commonly used filters in crossover networks are Butterworth and Bessel types. Very often the Butterworth is chosen for its more favourable frequency characteristic. For music reproduction a very important characteristic is the response to an input pulse, as figure 5 shows. From this diagram we see that the Bessel filter's characteristic is the better of the two and it also has less secondary oscillation. The Chebyshev filter's characteristic is not shown here as it is far worse than the other two.

We have designed our crossover filter in such a way as to enable it to be configured as either a Bessel or Butterworth type. It is then up to each user to choose which is more suitable for the particular application.

The complete crossover filter

Having dealt with the basic theory we have now come to the practical part of this article, namely describing the filter in its final form. The mono version is shown in figure 6. The same circuit is simply duplicated for stereo operation.

The power supply, seen at the lower left-hand side, has the usual format. In addition to this we see input buffer A1 and three output buffers, A2, A3 and A4. The output levels can be trimmed by means of P1 (low range), P2 (mid range) and P3 (high range). The input to A1 comes straight from the preamplifier, and the outputs from A2...A4 are fed directly to three power amplifiers.

The actual filter is based on A5...A12 and is set up as a fourth-order three-way system. The crossover frequencies are at 500 Hz and 5,000 Hz with the component values indicated. The three sections of the filter are fairly obvious: A5 and A6 define the cut-off point for the woofer (500 Hz here), A11 and A12 block all low and medium frequencies (less than 5,000 Hz in this example) to the tweeter, and the mid-range frequencies are passed to the appropriate output by the combination of high-pass filter A7/A8 and low-pass filter A9/A10.

The three-way 'character' of the filter is by no means fixed. A two-way system can be made simply by leaving out band-pass

4a

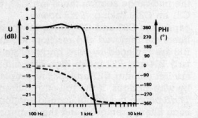

b

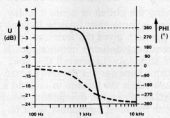

c

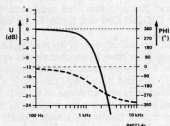

5

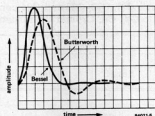

active crossover filter

Figure 4. The frequency and phase curves for the three most commonly used filter types are shown here — a = Chebyshev, b = Butterworth, c = Bessel. All three are fourth-order filters with a cut-off frequency of 1 kHz.

Figure 5. As regards reaction to a pulse input it is clear that the Bessel filter is far better than its Butterworth counterpart. It has a much shorter delay time and shows hardly any secondary oscillation.

filter A7...A10 and buffer A3. The same thing applies for the steepness of the roll-off. All the sections are, in principle, set up as 24 dB/octave filters but this could

easily be changed to 18 dB/octave or 12 dB/octave. This is done by leaving out some components or replacing them with wire bridges.

Figure 6. The complete circuit for the filter. If it is used as shown it has a characteristic of 24 dB/octave but this can easily be changed to 18 dB/octave or 12 dB/octave.

6

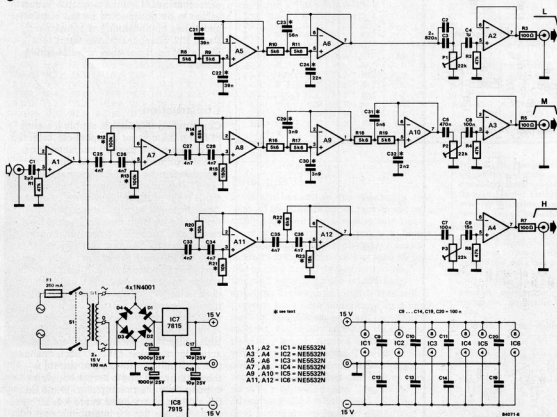







Setting the component values

Applying the circuit of figure 6 to any situation is quite easy. Start by looking at table 1, which gives the formulae for all the frequency-defining components. If you've suddenly discovered that your calculator batteries are flat don't panic — we have taken the trouble to include a few tables giving the component values to use with the most commonly used frequencies.

The first thing to be decided is the slope of the filters' characteristics. If 24 dB/octave is chosen the rest is very easy as the circuit remains just as it is. In the low-pass filter C21, C22, C23 and C24 correspond to C_A , C_B , C_C and C_D respectively

Table 1. The values of the frequency determining components in the circuit are calculated from these formulae. The filters may be either Bessel or Butterworth types.

Table 1

	Bessel	Butterworth
 <p>low-pass: 12 dB/octave</p>	$C_A = \frac{0.9076}{2 \times f \cdot R}$ $C_B = \frac{0.6809}{2 \times f \cdot R}$	$C_A = \frac{1.414}{2 \times f \cdot R}$ $C_B = \frac{0.7071}{2 \times f \cdot R}$
 <p>low-pass: 18 dB/octave</p>	$C_A = \frac{0.9548}{2 \times f \cdot R}$ $C_B = \frac{0.4908}{2 \times f \cdot R}$ $C_D = \frac{0.7960}{2 \times f \cdot R}$	$C_A = \frac{2}{2 \times f \cdot R}$ $C_B = \frac{0.5}{2 \times f \cdot R}$ $C_D = \frac{1}{2 \times f \cdot R}$
 <p>low-pass: 24 dB/octave</p>	$C_A = \frac{0.7298}{2 \times f \cdot R}$ $C_B = \frac{0.6699}{2 \times f \cdot R}$ $C_C = \frac{1.0046}{2 \times f \cdot R}$ $C_D = \frac{0.3872}{2 \times f \cdot R}$	$C_A = \frac{1.0824}{2 \times f \cdot R}$ $C_B = \frac{0.9239}{2 \times f \cdot R}$ $C_C = \frac{2.6130}{2 \times f \cdot R}$ $C_D = \frac{0.3827}{2 \times f \cdot R}$
 <p>high-pass: 12 dB/octave</p>	$R_A = \frac{1.1017}{2 \times f \cdot C}$ $R_B = \frac{1.4688}{2 \times f \cdot C}$	$R_A = \frac{0.7071}{2 \times f \cdot C}$ $R_B = \frac{1.414}{2 \times f \cdot C}$
 <p>high-pass: 18 dB/octave</p>	$R_A = \frac{1.0474}{2 \times f \cdot C}$ $R_B = \frac{2.0008}{2 \times f \cdot C}$ $R_D = \frac{1.3228}{2 \times f \cdot C}$	$R_A = \frac{0.5}{2 \times f \cdot C}$ $R_B = \frac{2}{2 \times f \cdot C}$ $R_D = \frac{1}{2 \times f \cdot C}$
 <p>high-pass: 24 dB/octave</p>	$R_A = \frac{1.3701}{2 \times f \cdot C}$ $R_B = \frac{1.4929}{2 \times f \cdot C}$ $R_C = \frac{0.9962}{2 \times f \cdot C}$ $R_D = \frac{2.5830}{2 \times f \cdot C}$	$R_A = \frac{0.5239}{2 \times f \cdot C}$ $R_B = \frac{1.0824}{2 \times f \cdot C}$ $R_C = \frac{0.3827}{2 \times f \cdot C}$ $R_D = \frac{2.6130}{2 \times f \cdot C}$

all R* have the same value of about 4.7 ... 10 kΩ

all C* have the same value of about 4.7 ... 10 nF

ively in table 1; for the low-pass filter in the mid-range section these are C29, C30, C31 on C32. Taking 18 dB/octave , capacitors C23 and C31 in the low-pass filters are removed and resistors R10 and R18 are replaced by wire bridges. Similarly R14 and R22 in the high-pass filters are left out and C27 and C35 are replaced by wire bridges. If the roll-off required is 12 dB/octave the whole second section of each filter is removed and the opamps just work as buffers. In this case C23, C24, C31 and C32 (in the low-pass filters) as well as R14, R15, R22 and R23 (high-pass filters) are removed, and resistors R10, R11, R18 and R19, together with capacitors C27, C28, C35 and C36, are replaced by wire bridges.

When the roll-off, cut-off frequency and type of filter have been chosen the values of the frequency-determining components, $C_A \dots C_D$ and $R_A \dots R_D$, can be selected from the formulae in table 1. The values needed for a large number of different cut-off frequencies have already been calculated and are indicated in table 2 (low-pass filters) and table 3 (high-pass filters). In these tables the components in question have the same designations as in table 1:

C21 ... C24 and C29 ... C32 are $C_A \dots C_D$; and R12 ... R15 and R20 ... R23 are $R_A \dots R_D$.

We have purposely not rounded off the values of resistors and capacitors to the nearest standard values to enable accurate values to be obtained by means of parallel and series combinations of components. Using E12 values makes the filters less than ideal so, if possible, use E24-series values.

Construction

Constructing this filter is simply a matter of fitting the correct components, selected according to the desired characteristics, into the printed circuit board shown in figure 7. For the 18 dB/octave or 12 dB/octave versions a number of components are left out or replaced by wire bridges. Apart from the supply transformer everything fits onto the same printed circuit board. For stereo operation, of course, two boards are needed, one per channel. The way in which the project is finished is a matter of personal taste. It could, for instance, be housed in its own case but then there will be three cables coming from the case and going to the power amplifiers, which is not such a good idea. A more logical idea is to include filter board plus three power amplifiers in the actual loudspeaker cabinet. Each channel (left and right, in the case of stereo) is then fed from a single screened cable coming from the preamplifier. While on the subject of screened cable it is advisable to use this for interconnecting the filter outputs and the power amplifier inputs.

If the filters and power amplifiers are built

Table 2

active crossover filter

f (Hz)	low-pass 12 dB/octave				low-pass 18 dB/octave				low-pass 24 dB/octave				
	Bessel		Butterworth		Bessel		Butterworth		Bessel		Butterworth		
	R = 5k6 (2 ×)	R = 5k6 (2 ×)	R = 5k6 (3 ×)	R = 5k6 (3 ×)	R = 5k6 (3 ×)	R = 5k6 (3 ×)	R = 5k6 (4 ×)	R = 5k6 (4 ×)	R = 5k6 (4 ×)	R = 5k6 (4 ×)	R = 5k6 (4 ×)	R = 5k6 (4 ×)	
(nF)	(nF)	(nF)	(nF)	(nF)	(nF)	(nF)	(nF)	(nF)	(nF)	(nF)	(nF)	(nF)	
100	257.9	193.5	401.9	200.9	271.4	142.0	214.9	568.4	142.1	284.2	207.4	190.1	285.5
200	128.9	96.8	200.9	100.5	136.7	71.0	107.4	284.2	71.0	142.1	103.7	96.2	142.8
300	85.9	64.5	133.9	66.9	90.4	47.3	71.6	189.5	47.4	94.7	69.1	63.5	96.2
400	64.5	48.4	100.5	50.2	67.8	35.5	53.7	142.1	35.5	71.1	51.9	47.6	71.4
500	51.6	38.7	80.4	40.2	54.3	28.4	42.9	113.7	28.4	56.8	41.6	38.1	57.1
600	42.9	32.3	66.9	33.5	45.2	23.7	36.9	94.7	23.7	47.4	34.6	31.7	47.6
700	36.8	27.6	57.4	28.7	38.8	20.3	30.7	81.2	20.3	40.6	29.2	27.2	40.8
800	32.2	24.2	50.2	25.1	33.9	17.8	26.9	71.0	17.8	35.5	25.9	23.8	35.7
1,000	25.8	19.4	40.2	20.1	27.1	14.2	21.5	56.8	14.2	28.4	20.0	19.0	28.6
1,500	17.2	12.9	26.8	13.4	18.1	9.47	14.3	37.9	9.47	18.9	13.8	12.7	19.0
2,000	12.9	9.68	20.1	10.0	13.6	7.10	10.7	28.4	7.11	14.2	10.4	9.51	14.3
2,500	10.3	7.74	16.1	8.04	10.9	5.68	8.59	22.7	5.68	11.4	8.30	7.61	11.4
3,000	8.59	6.45	13.4	6.70	9.04	4.73	7.16	18.9	4.74	9.47	6.91	6.36	9.52
3,500	7.37	5.53	11.5	5.74	7.75	4.06	6.14	16.2	4.06	8.12	5.93	5.44	8.16
4,000	6.45	4.83	10.0	5.02	6.78	3.55	5.37	14.2	3.55	7.11	5.19	4.76	7.14
5,000	5.16	3.87	8.03	4.01	5.43	2.84	4.30	11.4	2.84	5.68	4.15	3.81	5.71
10,000	2.58	1.94	4.01	2.0	2.71	1.42	2.15	5.68	1.42	2.84	2.07	1.90	2.86

Table 3

f (Hz)	high-pass 12 dB/octave				high-pass 18 dB/octave				high-pass 24 dB/octave			
	Bessel		Butterworth		Bessel		Butterworth		Bessel		Butterworth	
	C = 4n7 (2 ×)	C = 4n7 (2 ×)	C = 4n7 (3 ×)	C = 4n7 (3 ×)	C = 4n7 (4 ×)	C = 4n7 (4 ×)	C = 4n7 (4 ×)	C = 4n7 (4 ×)	C = 4n7 (4 ×)	C = 4n7 (4 ×)	C = 4n7 (4 ×)	C = 4n7 (4 ×)
(kΩ)	(kΩ)	(kΩ)	(kΩ)	(kΩ)	(kΩ)	(kΩ)	(kΩ)	(kΩ)	(kΩ)	(kΩ)	(kΩ)	(kΩ)
100	373.1	497.4	239.4	478.8	354.7	677.5	447.9	169.3	677.3	338.6	463.9	505.5
200	186.5	248.7	119.7	239.4	177.3	338.8	223.9	84.7	338.6	169.3	231.9	252.8
300	124.4	165.8	79.8	159.6	118.2	225.8	149.3	56.4	225.8	112.9	154.7	168.5
400	93.3	124.3	59.9	119.7	88.7	169.4	111.9	42.3	169.3	84.7	115.9	126.4
500	74.6	99.5	47.9	95.8	70.9	135.5	89.6	33.9	135.5	67.7	92.8	101.1
600	62.2	82.9	39.9	79.8	59.1	112.9	74.7	28.2	112.9	56.4	77.3	84.3
700	53.3	71.1	34.2	68.4	50.7	96.8	63.9	24.2	96.8	48.4	66.3	72.2
800	46.6	62.2	29.9	59.9	44.3	84.7	55.9	21.2	84.7	42.3	57.9	63.3
1,000	37.3	49.7	23.9	47.9	35.5	67.8	44.8	16.9	67.7	33.4	46.4	50.6
1,500	24.9	33.2	15.9	31.9	23.5	45.2	29.9	11.3	45.2	22.6	30.9	33.7
2,000	18.7	24.9	11.9	23.9	17.7	33.9	22.4	8.47	33.9	16.9	23.2	25.3
2,500	14.9	19.9	9.57	19.2	14.2	27.1	17.9	6.77	27.1	13.5	18.6	20.2
3,000	12.4	16.6	7.98	15.9	11.8	22.6	14.9	5.64	22.6	11.3	15.5	16.9
3,500	10.7	14.2	6.84	13.7	10.1	19.4	12.8	4.84	19.4	9.68	13.3	14.4
4,000	9.33	12.4	5.98	11.9	8.87	16.9	11.2	4.23	16.9	8.47	11.6	12.6
5,000	7.46	9.94	4.79	9.58	7.09	13.6	8.96	3.39	13.5	6.77	9.28	10.1
10,000	3.73	4.97	2.39	4.79	3.55	6.78	4.48	1.69	6.77	3.39	4.64	5.06

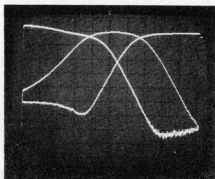

into the loudspeaker cabinet a special section should be screened off to house them. This will provide an acoustic barrier to prevent the electronics from playing havoc with the bass and it will also make it easier to cool the amplifiers.

Final tips

In an article such as this we cannot deal with all the details about how to set up a complete three-way active system but there are a few practical points to note. When talking about high-quality sound reproduction (which we can take as read) you should not allow yourself to be tempted by attractively priced loudspeakers of unknown origin. This will prove to be a false economy. Good names, such as Kef, Audax, etc., are the ones to look for, especially as these manufacturers generally supply quite a lot of information with their loudspeakers. This information about output, frequency characteristic, recommended cabinet dimensions and so on is of vital importance. Experimentation is very easy with the filter board shown here so our advice is to try various different types of filter arrangement. Your own taste will then decide if you prefer the 'sound' of a Bessel filter

Table 2. The component values for a number of commonly used crossover frequencies can simply be read off this table. Only the low-pass filter values are given here.

Table 3. Commonly used crossover points for high-pass filters are given in the first column here. The other columns list the appropriate component values that should be used.

Parts list

Resistors:

R1, R2, R4, R6 = 47 k
 R3, R5, R7 = 100 Ω
 R8 ... R11,
 R16 ... R19 = 5k6
 R12, R20 = RA — see tables
 R13, R21 = RB — see tables
 R14, R22 = RC — see tables
 R15, R23 = RD — see tables
 P1 ... P3 = 22 k preset

Capacitors:

C1 = 2.2 μ (MKT)
 C2, C3 = 820 n
 C4 = 1 μ (MKT)
 C5 = 470 n
 C6, C7, C9 ... C14,
 C19, C20 = 100 n
 C8 = 15 n
 C15, C16 = 1000 μ /25 V
 C17, C18 = 10 μ /25 V
 C21, C29 = CA — see
 tables
 C22, C30 = Cg — see tables
 C23, C31 = Cc — see tables
 C24, C32 = Cd — see tables
 C25 ... C28,
 C33 ... C36 = 4n7

Semiconductors:

D1 ... D4 = 1N4001
 IC1 ... IC6 = NE 5532N
 IC7 = 7815
 IC8 = 7915

Miscellaneous:

F1 = fuse, 200 mA
 slow blow
 S1 = double-pole mains
 switch
 Tr1 = mains transformer,
 2 x 15 V, 100 mA
 Heatsink for IC7 and IC8
 (optional)

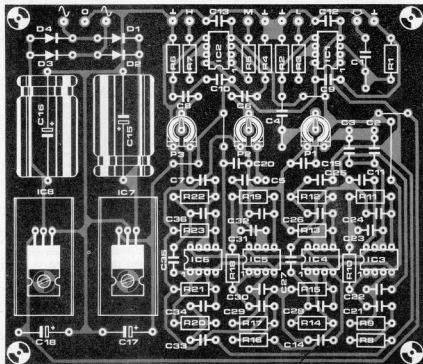
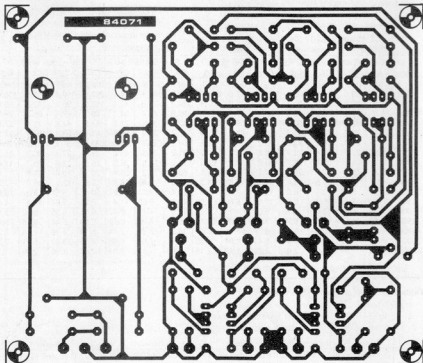

Figure 7. All the various types and combinations of filter, as described in the text, can be made by using this printed circuit board.

over that of a Butterworth type. Really it is essential to try different things as it is no simple matter to set up a good three-way system.

A good pair of ears is very important when setting up a loudspeaker system but we do not advise you to rely totally on

them. An appropriate instrument for any aspiring loudspeaker builder is the 'real-time analyser' described in the March, April and May issues this year. This is the test instrument to use for optimising an active loudspeaker's frequency characteristic.

In the June 1984 issue of *Elektor* we mentioned that connecting the digital cassette recorder described in February of this year to the output of a ZX81 can cause problems. Since then we have worked day and night (in spirit at least) to find a solution to help owners of this computer. This article deals with what we came up with.

digital cassette recorder
with the ZX81

digital cassette recorder with the ZX81

A few changes are needed both to the cassette recorder board and the ZX81 board and we will begin with the latter. Part of the circuit of the ZX81 is shown in figure 1. The computer's output signal must be amplified by making a new cassette output. This is done by connecting a 10 k resistor to the TV/TAPE output (pin 16) of IC1. All this means is soldering the resistor to R29 on the printed circuit board, as indicated by figure 1b. The output signal then has an amplitude of 150 mV_{pp}. The digital cassette recorder operates by driving the tape into saturation but the ZX cannot do this very easily as the impedance of its EAR input is too high. All that is required to lower the impedance is to cut the connection of R34 to EAR.

Moving on to the cassette recorder board, the hysteresis of A1 must be reduced by increasing the value of resistor R6 to 82 k. The amplification of the playback section is reduced by increasing the value of R20 to 10 k. The pause-level is improved by giving C8 a value of 10 n. The pair of relays, Re1 and Re2, can better be operated by hand. In normal use the video signal is present at the cassette output of the Sinclair with the result that the circuit will always select recording. The easiest way to solve this problem is to cut the copper track close to pin 6 of Re2 and link pin 6 to +12 V via a switch. For those who want the ultimate, a band-pass filter (with a centre frequency of about 5 kHz) can be added in the playback section. In this case C6 = 10 n, C8 = 2n2, C9 = 100 n and R20 remains 1 k. All that remains then is to connect a 560 p capacitor parallel to R21.

To enable the circuit to be calibrated a short program with a large loop must be written into the computer and the SAVE command is then given. The preset at the input, P1, must now be trimmed so that LED D11 lights properly. The analogue output, AN, is used when playing a recorded program back to the ZX81. For playback preset P3 must be set so that the program is read into the computer correctly. This can be seen by looking at the width of the black bars on the screen. There should be slightly more black than white visible.

When reading in a program it is important that preset P1 should be turned completely to ground or that the plug be removed from the input of the recorder

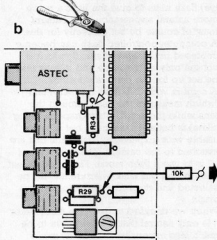
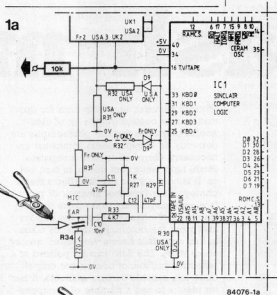

makes the storing of programs more reliable for Sinclair's smallest

circuit. Under no circumstances may LED D11 light during playback. This is essential to prevent cross-talk between the recording and playback sections. Probably the best solution is to short-circuit the input by using a 3.5 mm socket with a built-in switch. As soon as the plug is removed from the socket the input is then grounded.

When the modifications given here are carried out there will be joy in the hearts of Sinclair ZX81 users as this computer can finally be used with the *Elektor* digital cassette recorder. **M**

The flash units used by most photographers today are carefully designed to provide the correct amount of light. This is only true, however, in standard circumstances: with the flash mounted on the camera and the aperture set to the value recommended for the flash unit. This is not usually very creative and it does not take into account the practice of using a number of flash units and/or ordinary lights. In these cases either a lot of arithmetic or this flash meter is required. The most obvious advantage of this meter over similar ready-made units is its lower cost but its versatility is what really makes this design stand out from the rest.

flash meter

measures
light ...
... in a flash

Modern cameras, and flash units for that matter, now contain quite a lot of electronics to ensure that the photographs are correctly lit. It might seem somewhat unnecessary, therefore to have a separate (flash) light meter, but this is, in fact, not so. It is not only for special effects that a photographer (whether amateur or professional) might want to do more than simply fix the flash unit onto the camera and press the button. Photographs taken in this way often have a very 'hard' quality about them. The flash can be pointed at a reflective surface, of course, but only if there is a suitable surface available. A better idea is to use a number of (inexpensive) flash units to give the light a much more natural appearance. The camera must of course be set correctly for this. A computer-controlled flash can become confused in this sort of situation as it is not the only light source and it must also be set up for the camera's position. A camera with TTL flash measurement (which measures the flash through the lens while the actual photograph is being taken) is better in this case but is only usable with (expensive) flash units that are matched to the camera. The best idea of all is to use a flash meter. First make a test flash to find out what aperture should be selected and then take the actual photograph.

When we decided to design a flash meter it is only natural that it would have to be much less expensive than ready-made units but we decided that it must also be more versatile. Most available meters have a fixed measuring time and operate on the principle that if the flash occurs within this time most of the light will be measured. If the camera's flash synchronization time is longer than the meter's the effect of the extra (ambient) light will be neglected. The design proposed here has a measuring time that can be set to the same value as the camera. Normal light measurements can also be taken, with the result given in the aperture value (f1.4 ... 22 in half stops) that must be selected on the camera. This instrument is also fitted with an automatic

switch-off facility and provides the possibility of summing a number of measurements (for multiple exposures, for example).

The circuit

The power supply for the circuit, which is illustrated in figure 1, is provided by a 9 V battery. The automatic power switch-off circuit ensures that the battery lasts as long as possible. Pressing S4 causes C12 to be charged via D5 and at the same time darlington T5 is driven open thus connecting the negative pole of the battery to the circuit. After about 40 seconds capacitor C12 is discharged enough so that T5 is switched off.

Pressing S4 also fulfils another function, namely that T4 is caused to conduct momentarily via D4 and R14. This discharges C7 and any of the other four capacitors (C8 ... C11) that are in parallel with it. These capacitors play an essential role in this circuit. In the first place they convert the photo-current of D3 to an analog voltage, which, like the photo-current, is directly proportional to the amount of light present. The capacitors must also store the measured value with as little leakage as possible. We will return to this point later in the article. The light is measured by a BPW 21 photodiode (D3) which has the right sensitivity for our purposes. Its photo-current is conducted to ground by T3 when D3 is in its quiescent state. During the measuring time transistor T3 will be switched off so C7 and, depending on the states of switches S5 ... S8, some of the other four capacitors will be charged. In this circuit MOSFET T2 is used as a diode to provide a threshold for the photo-current when no measurement is being taken. Its very low reverse current also tends to prevent the capacitors from leaking.

The measuring sequence can be started in three ways. The first makes use of switch S1 and is the simplest way. The

flash unit(s) can be connected to the SYNC input. Pressing the switch causes flip-flop N3/N4 to toggle. This switches off transistor T3 so the photo-current flows into the capacitor network. At the same time the flash is triggered via the SYNC connection and counter IC2 is started by releasing its reset input. A clock signal is provided by oscillator N2/R6/C2 to enable the counter to run for a certain time, as decided by the position of switch S2. After a certain length of time the appropriate Q output of the 4040 will go high. The flip-flop then resets, the photo-current is again conducted to ground by T3 and the counter stops. The meter can now be reset by pressing S4 but if this is not done a second measurement can be taken and the total result is the sum of the two measurements.

The second method of triggering the

meter is by pressing the button on the flash unit to make a test flash. This is detected by D1 and the flip-flop is set via N1. The circuit consisting of R1, R2, C1 and T1 ensures that only sudden changes in the light intensity will affect the flip-flop. As a result this method is suitable only for flash measurements, not for normal light measurements.

The third way of triggering the circuit is by pressing the shutter release button on the camera. Either the flash itself (as in method two) or the shutter release switch in the camera (if this is connected to SYNC) will start the meter. The film in the camera will, of course, be exposed at the same time and it may then be cold comfort to know that the picture will be under or over-exposed due to the camera being incorrectly set.

Whichever of these methods is used the

flash meter

Figure 1. The circuit of the flash meter, as the diagram here shows, is straightforward. All the components should be freely available, except, perhaps, the photodiodes. Other types of high-speed photo detector (for D3) and infra-red photo detector (for D1) will probably work in the circuit but some of the other component values may have to be changed.

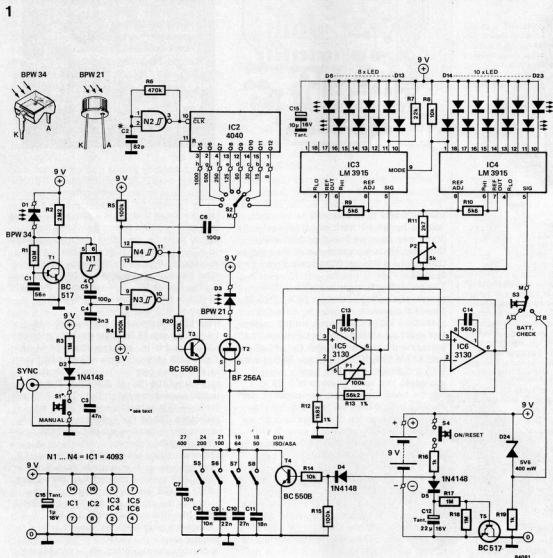
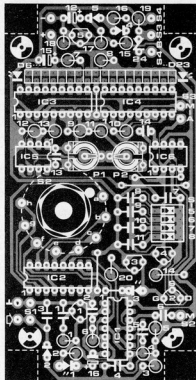
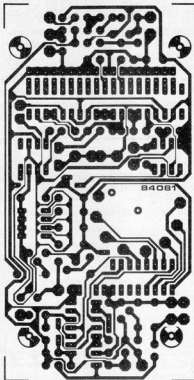

Figure 2. Depending on the type of case used for the circuit, it may be necessary to cut off the four corners of the printed circuit board to provide clearance for parts of the case.



Parts list

Resistors:

R1 = 10 M
 R2 = 2M2
 R3, R17, R18 = 1 M
 R4, R5, R15 = 100 k
 R6 = 500 k
 R7 = 22 k
 R8, R14, R20 = 10 k
 R9, R10 = 5k6
 R11 = 2k7
 R12 = 1k82, 1%
 R13 = 56k2, 1%
 R16, R19 = 1 k
 P1 = 100 k preset
 P2 = 5 k preset

Capacitors:

C1 = 56 n
 C2 = 82 p
 C3 = 47 n
 C4 = 3n3
 C5, C6 = 100 p
 C7, C8 = 10 n (MKT)
 C9 = 22 n (MKT)
 C10 = 27 n (MKT)
 C11 = 18 n (MKT)
 C12 = 22 μ /16 V Ta
 C13, C14 = 560 p
 C15 = 10 μ /16 V Ta
 C16 = 1 μ /16 V Ta

Semiconductors:

D1 = BPW 34
 D2, D4, D5 = 1N4148
 D3 = BPW 21
 D6 . . . D23 = LED,
 rectangular
 D24 = 5V6/400 mW zener
 T1, T5 = BC 517
 T2 = BF 256A
 T3, T4 = BC 550B
 IC1 = 4033
 IC2 = 4040
 IC3, IC4 = LM 3915
 IC5, IC6 = 3130

Switches:

S1, S4 = push button
 S2 = single-pole T2-way
 wafel switch
 S3 = single-pole spring-
 loaded changeover
 S5 . . . S8 = 4-pole DIL
 switch

photo-current is now stored as a certain voltage by the network of capacitors. Some way must be found of displaying this, ideally on a logarithmic scale such as that used for the aperture scale on a camera.

The capacitor voltage is buffered by means of a voltage follower (IC6). This is essential because in order to store the measured value the charge on the capacitors must be as constant as possible. The actual read-out is given with the aid of a pair of LM 3915 ICs. These are LED drivers with a difference as they have a logarithmic scale that rises in steps of 3 dB and can be used for either a bar-graph or dot display. In this case we will use the dot display mode as we only want to indicate a single aperture value at a time. A side-effect of having only one LED at a time lit is that the current consumption is kept low.

The buffered capacitor voltage is taken from pin 6 of IC6 and fed to the signal input of IC4 (pin 5). This IC compares the input to a reference set with P2 to determine which LED should light. A total of ten LEDs are connected to the outputs of IC4 so the range spans 30 dB. This is not sufficient for our purposes so it is extended by amplifying the IC4 signal voltage (with IC5) and feeding it into the signal input of IC3. The ratio of output to

input voltage that gives a range of 30 dB is 31.6 so this is the factor by which the signal must be amplified before being fed to IC3. In this way IC3 will drive its LEDs to indicate a value in the lower part of the total measuring range while IC4 takes over for the upper 30 dB of the range. The gain of IC5 is fixed by means of two 1% resistors, R12 and R13.

Two of the outputs of IC3 are not connected to any LEDs. The total number of LEDs used is 18, giving a range of 54 dB. Each 3 dB step corresponds to a half stop so the meter can be calibrated in apertures from f1.4 (D6) to f22 (D22). If the meter senses too much light LED D23 will be lit — this acts as a sort of overflow indicator. When the light intensity measured is too low no LED will light. Changing the reference voltage enables the scale to be set to whatever range the user selects, so it could run from f2 to f32 or f2.8 to f45, for example. The values of C7 . . . C11, which are used to set the meter to the right sensitivity for the film used (the film speed), can also be changed to suit personal needs or preferences.

A battery checking facility is provided by S3. When the battery is good an initial check should be made to see which LED lights. This will be dependent on the reference voltage set with P2. When the

meter is in service a battery check will light successively lower LEDs as the battery power decreases.

Construction

As we have already hinted the leakage losses of capacitors C7...C11 must be reduced as much as possible. This explains the use of MKT (Siemens polyester layer type) capacitors here. The design of the printed circuit board also incorporates some precautions in this respect. The junctions of C8...C11 with S5...S8 are surrounded by tracks that carry a similar potential (connected to the output of the voltage follower). There is none the less still a danger with home-made boards that the material itself could permit some leakage. The same problem could arise with the lacquer sprayed onto the board. It is, however, advisable to use a suitable (highly-insulative) lacquer as a protection against dampness. The printed circuit boards supplied by Elektor through the EPS meet all the above demands. There are two points to note when constructing this circuit. The rotary wafer switch, S2, must be fixed to the board by means of the lock-nut on its spindle. Points a...h are wired to points 1...8 respectively on the switch. If you use a single-pole 12-way switch the four remaining contacts are simply left open. The common pole of the switch is wired to the point marked M near T2 (refer to the section on calibration).

The setting for film speed is carried out with DIL switches S5...S8. These were chosen to reduce the amount of wiring around capacitors C7...C11. These switches must protrude significantly above the printed circuit board in order to come up to the level of the exterior of the case used. This is done by using an eight-pin wire wrap socket or a suitable number of ordinary eight-pin IC sockets.

A suitable case must be found for the circuit and everything must then be fitted into it. For our prototype we used a Verobox with dimensions of 120 x 65 x 40 mm but if you have another suitable box then by all means use it. The board must be mounted on spacers to leave room underneath for the battery and part of S2. The push buttons, S1, S3 and S4, also fit below the board, but are mounted on an aluminium bracket at the side of the case. This bracket can be fixed to the box by means of a pop rivet. If the SYNC socket is to be fitted it can be placed close to, and in parallel with, S1.

The photodiodes fit in one of the small sides of the case; D1 simply fits behind a suitable hole but D3 must be provided with a tube or pipe about 15 mm long and 8 mm in diameter. This tube, which can be seen in the photo of figure 3, should ideally be black and we will come back to its purpose in the next section.

The cover of the box must now be prepared by cutting three holes in it. The photo in figure 5 shows the end product and here we see that a bit of care and

3

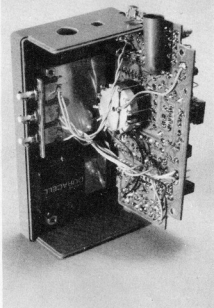

flash meter

Figure 3. The printed circuit board must be mounted on spacers to provide room for the battery, push buttons and the body of S2 underneath it.

attention is needed when cutting the holes for rotary switch S2, DIL switches S5...S8, and LEDs D6...D23 in order to produce a good result.

Calibration

To operate correctly the meter must be calibrated, beginning with compensating the offset of IC5. Pressing S4 switches on the unit for 40 seconds after which it will automatically switch off. This push button will therefore have to be pressed repeatedly. Temporarily short the non-inverting input of IC6 (pin 3) to ground and measure the voltage at pin 6 of IC5. Rotate P1 until a value of a few dozen millivolts is measured and then trim it until the value is reduced to zero volts but no further. Reconnect pin 3 of IC6. The oscillator must now be set so that the measuring time is the same as the shutter time in the camera. Although the oscillator

Figure 4. This view of the top of the printed circuit board shows how the DIL switches should be mounted in a wire wrap socket so that they finish flush with the top of the case. An alternative is to use a number of ordinary eight-pin IC sockets.

4

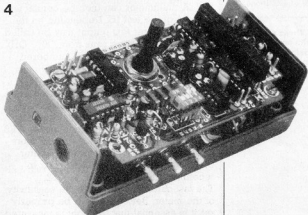

Figure 5. The finished unit is very easy to use because of the way everything is laid out. Rectangular LEDs should be used instead of round ones if possible as they improve the appearance of the unit.

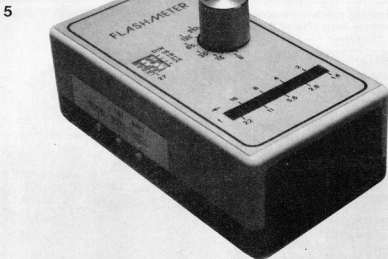
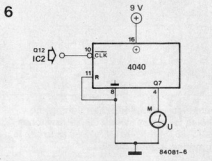

Figure 6. The oscillator is set up with the aid of this circuit. When connected correctly to the flash meter this 4040 causes the multimeter to deflect eight seconds after the flash meter is started (if the oscillator frequency is right).



is built of fixed components the differences in switching thresholds for the schmitt trigger given by various manufacturers can mean that the frequency is not correct. An oscilloscope is very handy in this case as the frequency measured at pin 10 of IC2 should be 32 kHz (giving a period of 31 μ s). Playing around with the resistance of R6 will enable this value to be achieved.

There is another method of checking this frequency, for those intrepid souls who do not have access to an oscilloscope. The longest measuring time is 1/8 of a second, which is a bit too fast to check with a wristwatch. The alternative is to use the circuit shown in figure 6, with the 4040's clock input connected to pin 1 (Q12) of IC2. A multimeter can then be connected to pin 4 of the test IC. Depending on the IC manufacturer this output may be called Q6 (if the numbering runs from Q0...Q11) or Q7 (when the outputs are numbered Q1...Q12). The common pole of S2 must be temporarily disconnected so that IC2 will keep counting rather than being reset. Counter IC2 is started by pressing S1 and after 8 seconds the multimeter should deflect. If this takes longer the value of R6 must be reduced. If the time is too short the resistance must be increased. After the frequency is correct remember to reconnect the common pole of S2.

The last calibration involves the sensitivity of the meter. Before this can be properly set it is essential that the light is measured

from the right angle. A 'naked' BPW 21 measures light incidence within a range of about 180° so the measured value would be higher than the actual amount of light that affects the exposure of a photograph. This problem is solved by mounting this photodiode away from the side of the case at the end of a short length of (preferably matt black) tubing.

The light meter in the camera is used to provide a reference value. Point both the camera and the flash meter at the same object from the same position then press S1 and trim P2 until the reading given by the meter is the same as that given by the camera. If P2 does not have a sufficient range for this to be done the values of C7...C11 must be changed. To increase the read-out (making the instrument more sensitive) these capacitor values must be reduced. Whatever values they have be sure that the various ratios of the capacitor values always remain the same.

The setting for film speed must, of course, be the same on both flash meter and camera. This adjustment is made with DIL switches S5...S8, where the sensitivity is reduced by closing more switches. At 27 DIN all four switches are open, for 24 DIN S5 is closed, 21 DIN requires S5 and S6 to be closed, at 19 DIN S5, S6 and S7 are closed and finally for 18 DIN all four switches are closed. The corresponding ASA and ISO values are given in table 1. During calibration it may occur that, especially at the highest sensitivity, the meter read-out may drift. This is due to leakage in C7...C11 so some sort of solution must be found. Make sure the relative section of the board is clean and dry. If the board is home-made spray some plastic lacquer on it and let it dry before trying again. It may be necessary to experiment with various different things to reduce the leakage as much as possible but this is well worth the effort. Finally, as regards using the meter: always take measurements from the camera's position. This is the only way to be sure of knowing how much light will fall on the film — and that's what it is all about. ■

Table 1

DIN	ASA	ISO	switches closed
18	50	50 ^a	S5...S8
19	64	64 ^a	S5...S7
21	100	100 ^a	S5, S6
24	200	200 ^a	S5
27	400	400 ^a	none

Table 1. These are the different film speeds that can be selected by means of the four DIL switches.

Opinions as to what is the most important part of a car are many and varied. For some people it is the seat they sit in for hours at a time, for others it is the engine under the bonnet, and for others again it is the built-in safety feature designed to save a life. There are differences of opinion, too, on smaller details, such as what is the instrument in the dashboard that could least be missed. The speedometer is generally the largest instrument making it easy to read at a glance. The most important instrument, however, is the tachometer rather than the speedometer, although most car makers consider it as an 'extra' or leave it out altogether.

digital tachometer

The importance of a rev counter in a car is greatly underestimated, largely because it is considered as 'something for sports cars' and run-of-the-mill car manufacturers are reluctant to fit anything that is neither a legal requirement nor guaranteed to increase sales. Of late a number of cars have become available with an indicator to advise the driver to change gear when the engine revs rise above the most economical level. This is one use of a tachometer; namely the pursuit of fuel economy. Another purpose of a rev counter is to enable a driver to make the best use of his engine's power — by which we do not mean the irresponsible carry-on of many 'boy racers'. The true professionals (rally drivers, race drivers) use the tachometer both to keep the engine within its power-band and to avoid damage due to over-exuberant use of the loud pedal. Finally, there is one other application where a tachometer is absolutely essential: when tuning a car.



Converting engine revolutions into digital pulses

The principle of our design for a digital tachometer can be gleaned from the block diagram of figure 1. Ignition pulses (at half the engine speed — for a four-cylinder four-stroke engine) are taken from the car's contact-breaker points (c.b.) and are formed into a more suitable signal by a pulse shaper. This section is carefully designed to ensure correct operation at all times. The pulses are used to trigger a monoflop which, in turn, provides the clock signal for three BCD counters. The data lines from the counters provide the information for the LCD drivers to tell them which segments must be enabled. An RC oscillator produces a signal which, when divided by 16, is used to provide the a.c. needed for the LCD display and drivers. Two more dividers are included to reduce the signal frequency even more and to provide two different values that can be selected by means of a switch.

The signal chosen in this way passes to a pair of monostable multivibrators (MMV) which provide latch pulses for the display and reset pulses for the BCD counters. The effect of this selection is to enable the measuring time (the time during which c.b. pulses are counted) to be either long (3 s), which gives an accuracy to 10 r.p.m., or short (0.3 s), in which case the display is accurate to within 100 r.p.m. To summarise, then, what actually happens is this. The pulses from the c.b. points are counted by three BCD counters. Every 3 or 0.3 seconds the count is transferred to the display and the counters are then reset.

The circuit diagram of figure 2 and timing chart shown in figure 3 provide more detailed information about the operation of the circuit. The timing diagram is divided into two sections, the first of which shows the progression of the ignition pulses through the pulse shaper and monoflop to become clock pulses for the BCD counters. The second part deals with

reads up to 9990 with an accuracy of 10 r.p.m. on an LCD display

the signal generated by RC oscillator R4/R5/P1/C4 and passed through the dividers in IC2 and one half of IC3 until it eventually triggers the latch pulse that appears at pin 3 of N2 and the reset pulse at pin 11 of N3.

Points to note

There is little reason to deal with the circuit in great detail but there are some points about it that are important. The RC oscillator, as we have said, is made up of resistors R4 and R5, preset P1 and capacitor C4. In order to ensure satisfactory stability it is essential to use a polystyrene capacitor for C4.

The update-frequency of the display is changed by switching the position of S1. Doing this affects three parts of the circuit. First, S1a selects the actual frequency (either 0.33 Hz or 3.33 Hz) which determines the measuring time. In the 'fast' position S1b feeds the BCD counter for the second digit (pin 2 of IC4) directly from monoflop N4. In the 'slow' position this signal is taken from the Q4 output of the lowest BCD counter. The final function of the switch, S1c, is to connect the clear line of the lowest counter (pin 15 of IC3) either to +5 V or to the output of N3. By doing this the least significant digit of the display is always zero when the 'fast' position is selected. Otherwise it is simply

reset, along with the other two counters, by the pulse from N3.

The significance of this switching is clear: one position gives optimum resolution and the other gives good readability. In the latter position one of the major disadvantages of many digital tachometers, namely that the display tends to flicker a lot, is avoided. The actual measuring time in this position is a compromise between resolution and readability and is more reliable. Only the lower three digits of the LCD display are used. The data about which of the segments should be visible is provided by the BCD counters in IC3 and IC4 via display drivers IC5...IC7. The display frequency inputs (pin 6) of the three drivers and the back plane of the display (BP, pins 1 and 40) are fed a 53.33 Hz signal from the Q4 output of IC2. All unused segments are also tied to this line. The appropriate decimal point (DP2) is kept on permanently by connecting it to the inverse of this latter signal. As shown in the diagram here the low frequency is selected and thereby the tachometer is at its more accurate setting.

Figure 1. All the various parts of the circuit can be recognised in this block diagram but as all embellishments are done away with the principle of operation can be clearly seen.

1

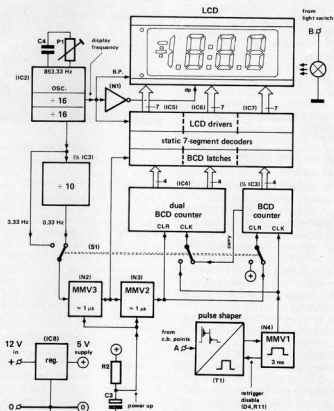

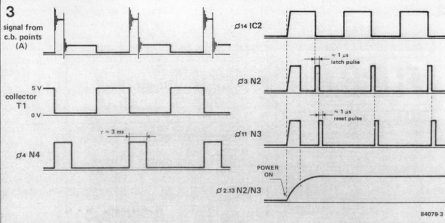

Figure 3. This timing diagram, as already stated in the text, is divided into two parts. These must be seen as essentially separate as their time-bases are completely different.

Figure 4. The printed circuit boards for the tachometer, as indicated here along with the component overlays, have been made circular in order to retain the most common shape for this sort of instrument.

ected to the board with two off-cuts from thick component leads, for example. We recommend that a 24 V bulb be used as a 12 V one may be too bright. The 'finishing touch' for our prototype was provided by fitting it into a short length of plastic pipe and adding a perspex 'front glass'.

Calibration and installation

The only part of the circuit that requires calibration is the RC oscillator. The auxiliary 'calibration' circuit shown in figure 5 is used to generate a 50 Hz signal

that is then fed into input A of the tachometer. As this signal corresponds to 1500 r.p.m. for a four-cylinder four-stroke engine the display should read 1.50. If this is not the case calibration is carried out by trimming preset P1.

Installing the tachometer is simply a matter of finding a suitable position for it in the car dashboard. It must then, of course, be connected to the appropriate points in the cars electrical circuit: A to the coil side of the c.b. points, B to an unused contact on the lights or dash-lights switch, 0 to the car's earth, and + to a fused +12 V line.

Parts list

Resistors:

R1, R2, R3, R7, R9, R10, R13 = 100 k
R4 = 4M7
R5 = 680 k*
R6 = 100 Ω
R8 = 47 k
R11, R12 = 22 k
P1 = 500 k linear preset

Capacitors:

C1, C2 = 22 p
C3 = 1 μ /16 V
C4 = 560 p polystyrene

C5 = 100 μ /25 V

C6, C7, C10, C11 = 100 n
C8 = 10 n
C9 = 33 n

Semiconductors:

D1, D3, D4 = 1N4148
D2 = 12 V/400 mW zener
T1 = BC 547B
IC1 = 4093
IC2 = 4060
IC3, IC4 = 4518
IC5... IC7 = 4056
IC8 = 78L05

Miscellaneous:

La1 = 12 V (24 V)*/50 mA bulb
S1 = switch, three-pole toggle
LCD = 3 1/2 digit LCD display, 12.7 mm character height, 40 pin two 40-pin sockets for mounting the LCD display six 16-pin IC sockets one 14-pin IC socket
* = see text

Using the tachometer

The various uses of a tachometer have been outlined at the beginning of this article so we will not repeat them here. One point must be made, however, concerning the switch, S1. The short measuring time should be selected when the car is accelerating as the least significant digit then reads zero and is thus less distracting. The 'slow' position, on the other hand is more suitable for motorway driving and particularly for tuning the car. In this latter context, indeed, it is quite feasible to use

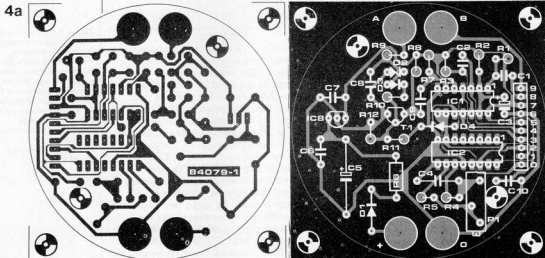

elektor INDIA

THE BASIC PRINCIPLE

BASIC (PART 1)

BASIC was introduced as a powerful and yet easily learned programming language for those who intend to use a computer as an aid in solving problems — without the need for extensive knowledge about how the computer actually works. This 'language' was developed at the Dartmouth College in the USA in the early sixties, and since then has become one of the most important programming languages. Increasing interest in computers as a hobby has helped to make BASIC highly popular. The name BASIC (Beginners All-purpose Symbolic Instruction Code) may give the impression that BASIC is an unsophisticated and over-simplified programming aid. However, quite to the contrary: BASIC may be a simple language, but it is very expressive and truly 'All-purpose'. At the same time, it is a good language for beginners, as the name suggests: programs can be written in BASIC without any prior knowledge of or experience with computers.

All users of microprocessors will agree that programming in 'machine language' is not a particularly easy way to develop a program. Machine language is the binary code that tells the computer exactly what to do, step-by-step and in the minutest detail. Programming in machine language requires detailed knowledge of the operating principles of the (micro-) computer in question, and it is frustratingly time-consuming.

For this reason, 'translation programs' are becoming more and more popular since they are used to translate higher 'programming languages', like BASIC and Fortran, into machine language. These higher programming languages are closer to normal English, and contain instructions like:

```
IF A = 0 GO TO (step) 21, rather than 'read register 03 (= A), compare with 0000 (= 0), etc. . . .'
```

By now, being able to understand BASIC has become a fairly standard feature of 'personal computers' and microprocessor development systems. For this type of application, a simplified derivative of the original (and extensive) BASIC language is often used: Tiny BASIC. The main difference between BASIC and Tiny-BASIC is that the mathematical programming capabilities of the latter are much more limited. Nevertheless, Tiny-BASIC is an extremely powerful programming language — especially when writing relatively simple programs. As microcomputers have become ever more popular and diversified, new variations of both the original Dartmouth BASIC and Tiny-BASIC have appeared. Virtually every supplier of microprocessors or microcomputers has developed his own version of BASIC, differing marginally from the original BASIC and Tiny-BASIC languages, and so a few dozen different BASIC 'dialects' are now in existence. One of these new variants is 'NIBL', derived from Tiny-BASIC and intended specifically for the National Semiconductor SC/MP microprocessor system.

Compilers and interpreters

BASIC, as such, is not tied to any particular computer. It is a programming language. However, to be able to run the program on any particular machine, the program will have to be translated from BASIC into the 'machine language' that the computer in question understands. This translation procedure can be performed by the computer itself, provided it has access to a program (in machine language) that tells it how to convert the BASIC instructions into its own language.

Storing a suitable translation program uses up valuable memory space, and so every attempt must be made to keep this program as short as possible. A short program, however, will have limited capabilities: it may not be able to translate all possible BASIC instructions, and it will be tailored to suit the capabilities that particular (micro-)computer. The result is that most translation programs are not only tied to a particular machine, they are also designed to translate one particular BASIC dialect. This is where the 'few dozen different dialects' come in. Fortunately, all these dialects have been

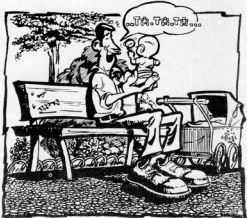

Introduction to a simple computer language

BASIC (PART 1)

made as similar as possible to 'basic BASIC' so that 'if you know one, you know them all' – up to a point.

Translating programs from BASIC into a machine language can be done in two different ways.

Compiler

The faster system is to first translate the whole program from BASIC into machine language, and only then start to run the actual program. Effectively, therefore, two distinct steps are performed consecutively: the program is first translated and then carried out (see figure 1). A translation program that works in this way is called a 'compiler'. Once the program has been translated it can be run as often as required, without any further need of the translating capabilities of the compiler.

Interpreter

The second possible system is to translate and perform the program line by line. The translation program, known as an 'interpreter' in this case, reads one step in the original BASIC program, 'interprets' it and causes it to be carried out immediately (see figure 2). Only then does it look at the next step. Effectively, a BASIC interpreter consists of a large number of very short programs ('sub-routines') in machine language, each of which can be started by one particular command in BASIC.

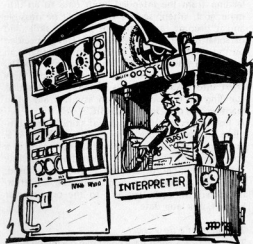

Advantages of an interpreter

This second system has advantages when (short) programs are to be run direct from the keyboard. Any programming or syntax errors ('bad language') are recognised immediately after they have been keyed in. Furthermore, when running short programs such as simple calculations, operation of the computer is very similar to using a pocket calculator: the result of each instruction is available immediately after it has been keyed in.

Disadvantage of an interpreter

When running larger programs, however, an interpreter has a major disadvantage when compared to a compiler. Subroutines that are used several times when running the program must be translated time and time again by the interpreter. A compiler, on the other hand, translates each subroutine only once. When the complete program, including all subroutines, is available in machine language the program itself is run. In this case, no matter how often a particular subroutine is called up the computer can get on with the job without having to call in the compiler again.

To sum it up briefly: a BASIC interpreter is useful when running short programs; a compiler has the edge when larger programs are considered. However, the choice between the two is not only a question of weighing the pro's and cons. The choice is limited to what the various manufacturers have to offer – unless, of course, one is prepared to write the necessary program . . . in machine language. BASIC translation programs for micro- and mini-computers are almost invariably interpreters.

Flow charts

Before attempting to write a program in BASIC, one must have a fairly good idea of the overall program 'picture'. The program can be seen as a road,

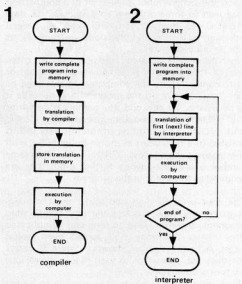

Figure 1. When a program is entered into a compiler, the first step is to translate the complete program into machine language. Only then is the program actually carried out by the computer.

Figure 2. An interpreter 'translates' the program line by line. After each line has been translated, the corresponding instruction is carried out immediately; only then is the next line translated.

79081 1

79081 2

BASIC (PART 1)

leading from the intended input data to an ultimate goal; often, several routes will be possible and it becomes a question of personal skill (and personal taste!) to choose the best. Having decided on the 'route', it can be sketched in 'shorthand' in a so-called flow chart. Writing a program in BASIC then becomes a question of 'translating' this flow chart into BASIC. For this reason, a good understanding of flow charts is an essential aid when learning 'the principles of BASIC'.

A flow chart is a quick way of sketching a complete program, in the same way that a block diagram can be used to give a general impression of a complex electronic circuit. When drawing a flow chart, a number of standard symbols are used; these help to make the program legible — both to interested third parties and to the programmer himself, at a later date ...

The value of a flow chart

The value of a good flow chart can hardly be overstressed: at the best of times a program, even when written in BASIC, is not particularly easy to follow. The flow chart is an important aid when writing the program; it is a clear way of explaining the program to others; and, last but not least, it is an important part of the 'instructions for use' when re-running the program at a later date.

Symbols used in flow charts

For the moment, only the most important symbols used in flow charts will be discussed. Their precise meaning and use will become clear in the examples which will follow. The most common

symbols are shown in figure 3. The first step in any flow chart is 'start'; this is contained in a so-called 'terminal' symbol, as shown in figure 3a. The same symbol is used, with the word 'end', to indicate completion of the program (figure 3e). The 'operations' in a program are contained in a rectangle, as shown in figure 3b; the actual operation is indicated by the text within the rectangle. This text should be as brief as possible: only those steps are listed that are important for an understanding of the complete program. In the example given, 'C = A + B' is sufficient; steps like 'fetch A', 'fetch B', etc. are omitted. A further limitation is that not all operations need be listed; a consecutive sequence of operations can often be summarised in a single rectangle, e.g. 'D = sin A + cos B + (C1)²'. Only in this way can a clear overview of extensive programs be maintained.

Most programs consist of more than a succession of operations. Somewhere along the line, the computer will be required to make decisions: 'Have all variables been checked?', 'Have all required points been plotted?', etc. This type of 'decision' is entered in the flow chart as a diamond (figure 3c); in this example, the values of C and D are to be compared. The computer must decide whether they are equal or not, and the route to be followed from here depends on the result of this decision: 'no' or 'yes'. A three-way decision is also possible, using the same symbol. The result of a comparison may lead to three different routes: if $C > D$, then (1); if $C = D$, then (2); if $C < D$, then (3). Several other comparisons and decisions are possible, as will be discussed later.

When running a program, the operator will often require the results of intermediate calculations or tests conducted by the computer. In this way, he can 'keep an eye on the program' and override it if necessary. To this end, the computer can print the relevant data on a terminal or video display unit (VDU). This printing of intermediate results is listed in a flow chart as shown in figure 3d, with the accompanying text 'PRINT ...'. The same symbol is also used when further input data are required at this point in the program.

The four symbols discussed so far are the mainstays of any flow chart. Long and complicated programs, however, lead to long and complicated flow charts that may well spread over several pages. A further symbol, shown in figure 3f, caters for this: the 'connector' is used to join the various parts of a flow chart.

Using only these symbols, it is possible to 'rough out' almost any program. As mentioned earlier, the examples given further on will help to clarify the use of flow charts and the various symbols used.

3

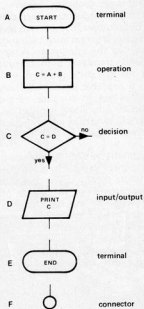

7901 3

Figure 3. The main symbols used in a flow diagram.

Calculator or computer?

Cheap pocket calculators have become commonplace. All of these units have one similar capa-

BASIC (PART 1)

bility: they can perform the four basic mathematical operations (add, subtract, multiply and divide).

Calculations using these four basic functions can also be performed by a computer. As we will see, a computer is in fact capable of performing much more complex calculations. Which is just as well for manufacturers of computers — it is unlikely that they will be forced off the market by manufacturers of pocket calculators. Computers and calculators are definitely not the same thing.

A significant difference between computers and calculators is the keyboard. In calculators, the keyboard is an integral part of the unit — in fact, the cheapest calculators consist only of the keyboard, the display and a single integrated circuit. The 'keyboard' of a computer, on the other hand, will normally be a completely separate unit. Commands and other information are entered into a computer by means of a so-called 'terminal', which is even in some cases linked to the computer by means of standard telephone lines.

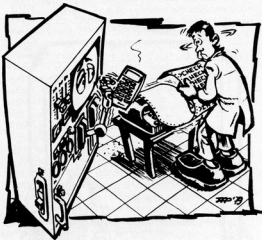

The terminal is the link between man and machine: it makes 'conversation' between the two possible. The keyboard of a terminal is very similar to a normal type-writer keyboard, and up to a point its function is also similar. In some cases the terminal will actually type on normal paper, in others the text appears on the screen of a 'Video Display Unit' (VDU). Keyboard and VDU together are then referred to as the terminal; one example is the 'Elekterminal' recently described in *Elektr* (November/December 1978).

The second major difference between calculator and computer is the way in which the results of calculations are presented. A pocket calculator only has a numeric display: i.e. a limited number of digits light up to indicate the result of a calculation. A computer, on the other hand, can be programmed to type the result neatly on paper (using both letters and numerals) or to give an extensive 'print-out' on the screen of the VDU in the terminal.

'Hello' in computerese . . .

Let us assume that we have a simple computer, a BASIC interpreter and a terminal. The interpreter will 'say Hello' as soon as the translation program is started. The initial procedure varies from computer to computer: in some cases it is sufficient to switch on and operate a reset button (as will be the case in the Elektor NIBL computer); sometimes a more extensive procedure must be carried out. The complete procedure is always described in the relevant instruction manual.

The way in which the computer announces its readiness is determined by the interpreter program. Normally this first announcement will be as short as possible, in order to save memory space. A few examples:

```
ROM BASIC 1.0
READY
#
```

```
DCE TINY BASIC V1.0
OK
>
```

These two initial announcements are provided by a BASIC interpreter for the Motorola M6800 microprocessor, and a DCE Tiny BASIC interpreter for the 8080, respectively. These announcements are relatively 'wordy'. By comparison, the AMI S6800 Tiny BASIC interpreter merely prints a colon (:) at the beginning of a line. Similarly, NIBL prints only one symbol, >, at the start of a new line. These symbols (:, > or #, at the start of a line) are called 'prompts'. A prompt indicates that the interpreter is ready to receive information (from the keyboard).

As mentioned earlier, the complete initial procedure — including the type of prompt that is to be expected — will be described in the instruction manual supplied with the computer or interpreter program.

Program lines

No matter what programming language is used (BASIC or any other), the program must always be listed in numbered lines. One line may contain more than one instruction, provided they are clearly separated by means of a colon (:).

Since a computer, once started, will keep going until it is told to stop, all programs must be terminated by the instruction END. A very brief program might therefore be listed as follows:

```
10 INSTRUCTION 1
20 INSTRUCTION 2
30 INSTRUCTION 3
40 INSTRUCTION 4: INSTRUCTION 5
50 INSTRUCTION 6
50 END
```

It is common practice to locate the first instruction on line 10, and the following instructions on lines 20, 30, etc. Why the gaps? In practice, the first attempt at writing a program is rarely complete

BASIC (PART 1)

— one almost invariably overlooks one or more necessary instructions. By initially placing the instructions at ten line intervals, it becomes possible to add further instructions at a later date without having to rewrite the rest of the program — by using the intermediate lines. An example is line 35 in the brief program listed above. If the worst comes to the worst, up to 9 full lines of instructions can be added without having to rewrite any other part of the program. The interpreter will see to it that instructions added at a later date will be carried out at the correct point in the program. When the program is run, the computer will simply carry out all the instructions in the order in which they are numbered, without worrying about any intermediate gaps.

It is also possible, at a later date, to modify or delete instructions if required. The procedure is simplicity itself: to modify an instruction the line number is typed in, followed by the new instruction. Deleting an instruction is accomplished by typing in the line number, immediately followed by 'CR' (Carriage Return).

Carriage Return is as important when writing a program as it is on any normal typewriter. At the end of a line — or, for that matter, whenever a new line is required — the CR key must be used. The interpreter will respond with a 'prompt' symbol, after which the new line number and the next instruction can be keyed in. If the CR key is forgotten, the remainder of the line will be lost, the text will 'run off the paper'.

It is also possible to key in program lines without assigning them a line number. In this case, the instruction(s) will be carried out by the interpreter as soon as the CR key is operated. In other words, the computer will then operate like a pocket calculator, carrying out instructions immediately and then forgetting that they ever existed.

Statements

Like any other language, BASIC uses words, and they are derived from English, which is a help. The vocabulary is limited and simple, so that even beginners can pick it up quickly! A word in a programming language is an instruction to the computer to perform one particular operation. These instructions are normally called 'statements'. The statements described in the first two parts of this series are common to all BASIC and Tiny BASIC dialects. Since they have the same meaning in all these dialects, it is possible to make a gradual transition from BASIC in general to Tiny BASIC in particular.

When it comes to Tiny BASIC dialects, NIBL will be of particular interest — since it is suitable for the Elektor SC/MP system. However, the differences between NIBL and the other BASIC dialects are so marginal that a general understanding of BASIC can be gained.

PRINT and RUN

A simple calculation, performed on a pocket calcu-

lator, leads to a visible result on the numeric display. Not so for computers. The computer is quite happy to keep the final result to itself, storing it somewhere in memory, unless it is specifically ordered to print out this result. If the human operator would also like to know the final result, he must make use of the PRINT statement.

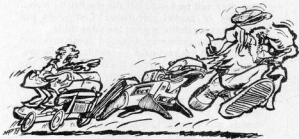

If a short calculation is to be performed immediately, without actually storing the program, line numbers can be omitted and the total print-out could be as follows:

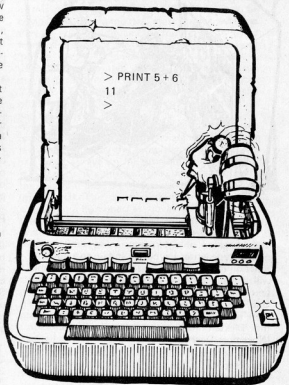

After the first 'prompt' symbol, the instruction PRINT has been keyed in, immediately followed by the calculation required. When the CR key is then operated (this does not appear on the display) the interpreter immediately ensures that the statement is carried out and that the result is

BASIC (PART 1)

printed on the next line. It then returns to the beginning of the next line and prints a further prompt symbol, indicating that it is ready for the next statement.

If a program for the same calculation is keyed in, this will be stored in the computer memory, ready for re-run at any time. Writing such a program is simplicity itself:

```
> 10 PRINT 5 + 6
> 20 END
> RUN
11
BRK AT 20
>
```

After the program has been typed in (the first two lines), the computer must be told to carry out these instructions. This is accomplished by typing 'RUN', followed by CR. The computer then performs the calculation and prints the result (11) on the next line. The main difference between this program and the short calculation performed above is that if, at a later date, 'RUN' is again keyed in the computer will repeat the calculation and again print the result. If only the short calculation had been performed, the computer would either 'look blank' (printing a ? , for instance) or else run some previous program.

After printing the result of the calculation, the interpreter has produced the print-out 'BRK AT 20'. This is an abbreviation for 'Break at 20', and signifies that the program has been terminated at line 20: the END statement. This 'final call' varies from one interpreter to another: 'BRK AT ...' is the termination announcement as provided by NIBL. Other interpreters often print out 'READY'. This termination announcement is always followed automatically (as part of the interpreter program) by a CR and LF — carriage return and line feed, respectively — and a prompt symbol.

The possibilities of a PRINT statement are more extensive than this simple example may suggest. It is also possible to print a full line of text, or a combination of text and results of calculations. A simple extension of the previous example may help to clarify this:

```
> 10 PRINT "5 + 6 ="
> 20 PRINT 5 + 6
> 30 END
> RUN
5 + 6 =
11
BRK AT 30
>
```

Adding quotation marks around $5 + 6 =$ on program line 10 alters the meaning of this instruction from 'calculation to be performed' to 'text to be printed'. The text $5 + 6 =$ is printed without

modification, and followed automatically by CR and LF. Then line 20 is read and the instruction is carried out; this line is identical to line 10 in the previous example and the result is the same, the calculation is performed and the result is printed on the next line.

This print-out is less than ideal, since text and result are printed on different lines. It would be neater to have text and result on the same line.

This result can be achieved by adding a semi-colon after the required text, as follows:

```
> 10 PRINT "5 + 6 =";
> 20 PRINT 5 + 6
> 30 PRINT
> 40 PRINT "5 + 6 ="; 5 + 6
> 50 END
> RUN
5 + 6 = 11
```

```
5 + 6 = 11
READY
>
```

The effect of the semi-colon is to suppress CR and LF, so that the next PRINT instruction is carried out on the same line. The semi-colon can also be used to separate PRINT statements, as illustrated in line 40, producing the same final results as lines 10 and 20.

One final point remains to be clarified in the program example given above. The PRINT statement that is listed on line 30 may appear superfluous. However, since no text or other instruction is included after this PRINT statement, the computer will print the corresponding result on that line: nothing! In other words, this is one way of making the computer leave a one-line gap in the total print-out.

The most important possibilities of the PRINT statement have now been discussed. A few further possibilities will be dealt with later, after some other related statements have been explained.

Questions

1. What is the difference between 'standard' BASIC and Tiny BASIC?
2. Why is a Tiny BASIC dialect often used for micro-computers?
3. What is the main difference between a compiler and an interpreter?
4. What are the advantages, and what are the disadvantages, of an interpreter?
5. How did the various 'dialects' of BASIC come into existence?
6. Why is a flow chart so important?
7. What is a 'prompt'?
8. Why should a program line (in a BASIC program) always be numbered?
9. What does the CR key do?
10. What will the computer print out as a result of the following instruction in BASIC:
PRINT 3 + 4 + 5

BASIC (PART 1)

GLOSSARY

binary code

Binary numbers consist only of ones and zeroes. For example, the count '1, 2, 3, 4, 5' becomes, in binary: '001, 010, 011, 100, 101'.
See also: **machine language**.

character

Any symbol in a print-out: letters, numerals, punctuation marks, etc.

compiler

Translation program from a **programming language** to a **machine language**. A compiler translates the whole **program** before any part of it is carried out.

CR

Carriage Return (return to beginning of line in display).

development system

Computer system that is designed specifically as an aid when developing **programs** (i.e. when writing a new program).

flow chart

A graphic means of illustrating the basic 'lay-out' of a **program**.

instruction

Describes the next step that the computer must carry out. A **program** consists of several instructions.
See also: **statement**.

instruction code

The equivalent, in **machine language**, of an instruction. An instruction code is a binary number.

interpreter

Translation program from a **programming language** to a **machine language**. An interpreter causes each line in the **program** to be carried out immediately after it has been translated.

LF

Line feed (move to next line in display). This is normally carried out in conjunction with **CR** (carriage return).

machine language

Binary code in which all **instructions** must ultimately be expressed, if they are to be understood by the computer.

memory space

Part of the memory that is (or can be) used.

NIBL

National Industrial BASIC Language, a dialect of Tiny BASIC suitable for the National Semiconductor SC/MP systems. Pronounced 'nibble'.

program

A sequence of **instructions** which, when carried out in the specified order, will cause the computer to perform some specific task.

programming language

A 'language' in which **programs** can be formulated. Programming languages are closer to 'plain English', and therefore easier for the operator to master.

prompt

Symbol that indicates that the computer is ready for the next **instruction**. Examples: >, :, #.

subroutine

A small, complete **program** that will normally be carried out several times in the course of the main program.

statement

Instruction, in BASIC, telling the computer to perform a specific task. Examples: PRINT, END.

terminal

Unit that is intended specifically for communication between man and machine. It consists of an input unit (e.g. a keyboard) and an output unit (e.g. printer or **VDU**).

VDU

Video Display Unit, which allows the computer to 'print' its output on a (TV) screen.
See also: **terminal**.

Summary of symbols and statements used in part 1.

{	
: V#	These so-called 'prompt' symbols can be printed at the beginning of a line.
:	Colon, used as separation between statements, if more than one statement is to be printed on the same line.
+	Symbol for the addition operation.
PRINT 'ABCD'	The symbols entered in quotation marks will be printed (in this case: ABCD).
PRINT 3+4	The expression after the PRINT statement will be performed and the result will be printed (in this case: 7).
PRINT	The semi-colon can be used to separate groups of symbols and/or expressions to be printed. A semi-colon at the end of a PRINT statement will result in the following PRINT statement being carried out on the same line.
10 STATEMENT	A number at the beginning of a program line indicates that the following statement is part of the program.
END	This statement indicates the end of a program.
RUN	This command causes the computer to start carrying out the program.

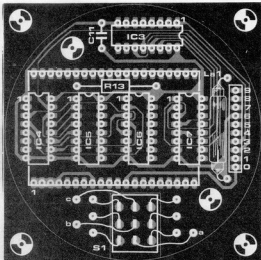
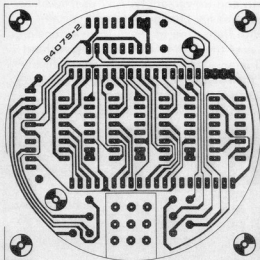

this tachometer purely as an aid to tuning a car as there is then plenty of time to read the display and take advantage of its accuracy.

The majority of cars today have four-cylinder four-stroke engines so this circuit was designed mainly for this type of engine. The tachometer can, however, be used with most other engine configurations. Full details of this facility are given by the notes in the margin beside figure 2.

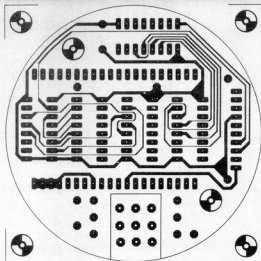

5

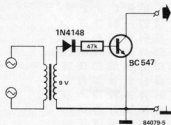

Figure 5. This circuit can be used for calibrating the tachometer. Its purpose is to simulate the c.b. pulses (at 50 Hz) normally fed into the circuit at point A by an engine turning at 1500 r.p.m.

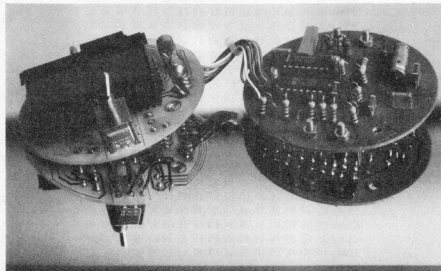

Photo 1. Here we see the two boards that make up the tachometer. To achieve the compact form shown in the photo at the beginning of this article the two are mounted one above the other in the form of a 'sandwich'.

The Ohio Scientific disk operating system, as applied to the Junior Computer, has shown its worth and its versatility. Any user familiar with the DOS software can quite easily change it to add certain options such as those dealt with here. One of these is an extension of the DIR instruction (which lists the files in the directory without using BEXEC) and the second is an extension of PUT (stores files without the need to first add their names to the catalogue). To make it all the more interesting we also introduce a 'turbo byte'.

F. Schmidt

two new commands for the Junior Computer with DOS

DIRPUT

It is surely a sign of progress (?) when in order to make our lives easier, using computers, we have to complicate them even further, with these same computers. The end result decides whether it has been worth the trouble and certainly in the case of the few changes described here the benefits are clear.

Two extra commands

The new 'DIRECTORY' instruction of the DOS (its shortened form is 'DI'), when it is not followed by a track number, provides a listing of the contents of a diskette from the DOS command interpreter *without having to call some BASIC program*. It is still possible to use the original form

DI TT, where TT is the number of a track. The result in that case gives the number of sectors in the track. It is important to remember that only the first half of the directory (32 of the 64 possible file names) can be accessed with the new instruction. This is not usually such a drawback as it is very rare that a diskette contains more than about thirty different files.

The existing PUT *filename* instruction only allows a file to be stored if the name '*filename*' already exists in the directory, and that is not very user-friendly. From now on, however, it will be possible to give the PUT command with the name of a file that does not yet exist in the directory. When the DOS does not find this filename it tests to see if there are enough

Table 1.

	0	1	2	3	4	5	6	7	8	9	A	B	C	D	E	F
E400:	AC	E5	2C	B1	E1	C9	20	30	0A	C9	23	F0	06	20	2E	2D
E410:	4C	F3	29	20	73	20	0A	20	20	20	44	49	52	45	43	54
E420:	4F	52	59	0D	0A	0A	00	20	1F	E5	A9	79	05	10	A9	2E
E430:	05	11	20	34	E5	F0	20	A0	00	B1	10	20	43	23	C8	C0
E440:	06	D0	F6	20	73	20	20	20	00	A0	06	B1	10	20	92	2D
E450:	20	73	20	20	20	20	00	A0	07	B1	10	20	92	20	20	73
E460:	2D	0D	0A	00	20	41	E5	D0	C9	60	20	54	27	20	0A	26
E470:	20	66	26	4C	61	27	60	AA	60	A0	40	0A	40	C9	DF	D0
E480:	29	C0	20	D0	25	A5	E0	00	E5	2C	20	1F	E5	20	70	E5
E490:	AD	70	3A	05	10	A0	A2	FF	E0	E0	20	F0	7E	00	30	0E
E4A0:	BD	AE	E5	F0	F3	A4	10	4C	90	E4	A9	0C	D0	6A	30	0A
E4B0:	E5	10	AA	A9	00	10	F8	69	01	CA	D0	FB	D0	40	20	50
E4C0:	E5	D0	52	60	A0	06	91	10	C0	10	F0	6D	7D	3A	E9	00
E4D0:	D0	91	10	30	A5	10	ED	E5	2C	05	10	B0	02	C6	11	AC
E4E0:	E5	2C	A2	06	B1	E1	C9	23	F0	04	C9	19	10	06	C8	91
E4F0:	E1	00	A9	20	91	10	C0	CA	D0	EA	A9	01	00	5E	20	0D
E500:	5F	26	A9	79	05	FE	A9	2E	05	FF	20	54	27	20	E1	27
E510:	60	60	4C	D0	20	60	A9	0F	4C	40	2A	A9	0E	D0	F9	A9
E520:	79	05	FE	A9	2E	05	FF	A9	12	20	BC	26	A9	01	00	5E
E530:	26	4C	1A	20	A0	05	B1	10	C9	23	D0	04	00	10	F7	C0
E540:	60	10	A5	10	69	00	05	10	A5	11	69	00	05	11	C9	2F
E550:	D0	00	A5	10	C9	79	D0	02	A9	00	60	A9	79	05	10	A9
E560:	2E	05	11	20	34	E5	F0	07	20	41	E5	D0	F6	A9	FF	60
E570:	A2	27	A9	00	9D	AE	E5	CA	10	FA	0E	AE	E5	A9	79	05
E580:	10	A9	2E	05	11	20	34	E5	F0	1E	A0	07	B1	10	00	40
E590:	A2	FF	30	F0	E9	01	E0	B0	FB	60	30	F1	10	D0	A0	A9
E5A0:	FF	9D	AE	E5	CA	00	10	F9	20	41	E5	D0	D0	60		

Table 1. Two new functions, DIR and PUT, can be incorporated into the Junior Computer's disk operating system by loading this program in the appropriate place.

free tracks to store the file. Assuming there is enough space the new filename is included in the directory and the PUT instruction is executed normally. As with the new DIR command, this new PUT instruction only considers the first half of the directory. If the available tracks contain non-documented data (with no file name) they will be destroyed by the new file. None the less the new PUT command can only be used with appropriately formatted diskettes. If the DOS does not find enough free tracks for the file it gives the message 'ERR#E' and if there is no space in the first half of the directory for the new file name the message 'ERR#F' appears.

How it is done

As we are making some fairly significant changes we may as well take the opportunity to make a small alteration to the HO and SE instructions which load the read head but do not unload it. Replace the D4HEX at 26A5HEX by D2HEX and then carry out several read and write operations on a number of successive tracks. If this works properly your floppy disk unit has accepted the increase in operating speed. If, on the other hand the system does not respond you will have to revert to the original data and forget about the 'turbo' byte for the moment...

In order to carry out the modifications to your system simply follow the instructions given below. In the interests of simplicity the new program is located in RAM at E400HEX. There are other, shorter but more complex, possibilities but we prefer to avoid them here. Start by making a copy of the Ohio Scientific tutorial disk 5 in the version used for the Junior Computer. Then make the following changes to this copy:

- Start the extended monitor (EM) and load the hexdump from table 1 at the address indicated.
- Save this program with the instruction !SA 12,5=E400/2 (it just so happens that sector 5 of track 12 is free)
- Load tracks 1 and then 0 as follows:
!CA 4A00=01.1
:!EX 41FD=00
- The extended monitor allows the changes given in table 2 to be made quite easily after giving the command:
:D420Q42A0
A number of addresses must then be changed:
4E42: FF 4E43: E3
4663: 4C 4664: 6A 4665: E4
4E0D: 76 4E0E: E4
and finally
46A5: D2
to speed up the head movement.
- Reload the contents of track 1 on the disk with the instruction !SA 01,1=4A00/8
- Load the track 0 control routine as follows:
!CA0200=06,4
and then start it with the command

Table 2.

	0	1	2	3	4	5	6	7	8	9	A	B	C	D	E	F
4280:	8C	00	23	A2	01	8E	C6	2A	A9	00	85	FE	A9	E4	85	FF
4290:	A9	12	20	BC	26	A9	05	80	5E	26	20	67	29	4C	B3	22

Table 3.

```

80 PRINT: PRINT: PRINT: PRINT
90 PRINT "CHOOSE ONE OF THE FOLLOWING OPTIONS:"
100 PRINT
110 PRINT " - ENABLE DOS-EXTENSIONS (1) "
120 PRINT " - DISABLE DOS-EXTENSIONS (2) "
130 PRINT
140 PRINT SPC(7) : INPUT "YOUR CHOICE ";CHOICE
150 IF CHOICE=1 OR CHOICE=2 GOTO 200
160 END
200 DIM ADDR(6),BYTE(6)
210 REM ADDRESSES
220 DATA 11842,11843: REM POINTER TO D1-1
230 DATA 9827,9828,9829: REM JMP TO HOME
240 DATA 11789,11790: REM POINTER TO PUT
250 REM DATA
260 DATA 255,227,76,106,228,118,228
270 DATA 40,43,32,138,38,75,42
280 REM LOAD MACHINE LANGUAGE ROUTINE FROM TR 12, SEC 5
290 IF CHOICE=1 THEN DISK!"CA E400=12,5"
300 REM CHANGE ADDRESSES IN DOS
310 FOR I=0 TO 6: READ ADDR(I): NEXT
320 IF CHOICE=1 GOTO 340
330 FOR I=0 TO 6: READ DUMMY: NEXT
340 FOR I=0 TO 6: READ BYTE(I): NEXT
350 FOR I=0 TO 6: POKE ADDR(I),BYTE(I): NEXT
360 ON CHOICE GOTO 400,500
400 PRINT: PRINT " --- DOS-EXTENSIONS ENABLED ---"
410 PRINT "!!! MEMORY FROM $E400 ON IN USE !!!"
420 NEM
500 PRINT: PRINT " --- DOS-EXTENSIONS DISABLED ---"
510 NEM

```

!GO 0200

Save the contents of track 0 by means of
W4200/2200.8
and the modifications are finished.

The versatile solution

Rather than making any permanent changes to the existing DOS it may be better to be a bit cautious, which is possible with the BASIC program shown in table 3. This is, in effect, a DOS extensions enable/disable switch. The RAM between E400HEX and E5ADHEX remains usable if you decide to include the new PUT and DIR instructions, but there is no longer any need to manually change the contents of tracks 0 and 1 as the BASIC program takes care of this. If you decide to place the machine code program somewhere other than sector 5 of track 12 do not forget to change the load instruction in the program of table 3 (DISK!"CA E400=12,5").

DIRPUT

Table 2. These are the changes that must be made to track 0 of disk 5. The modifications to track 1, and the procedure for saving tracks 0 and 1, can be found in the main text.

Table 3. If you are reluctant to permanently modify the contents of tracks 0 and 1 of your main diskette or if you do not want to monopolise part of the RAM this BASIC program can be used according to the instructions given in the last paragraph of this article.

SCART is the name given to the new plug-and-socket connection between a television receiver and associated equipment such as a video recorder or stereo amplifier. The name is an acronym of Syndicat des Constructeurs d'Appareils Radiorécepteurs et Téléviseurs, the French association of radio and television receiver manufacturers. This association decided some time ago to terminate various inputs to, and outputs from, TV receivers into a 21-way socket, which is becoming a European standard.

SCART adapter

European standard for video and audio connections

Figure 1. The 'old' arrangement will undoubtedly pertain for quite a few years to come in many households. If you want to get more from your television set, however, you need a SCART connector. Only that will, for instance, allow you to make full use of all the possibilities offered by the connection between your personal computer and colour television set.

The reasons for the adoption of a multi-way connector are not hard to find. Not so long ago, all that needed to be connected to the TV receiver were the mains supply and the aerial. Nowadays there is the video recorder, video disk player, games computer, Prestel, and the facility to feed the audio to your hi-fi installation. The cables required for all these connections would make the back of your television set look like a hi-fi rack. Another aspect of this is that even if sockets for all these connections were provided on the TV set, they would more often than not be of a different type than the plugs provided

with the recorder or games computer. And special cables or adapters are not exactly cheap!

Connections old and new are shown schematically in figure 1. It is clear that those between a video recorder and the TV set are quite simple: a disadvantage is, however, that the r.f. signal is taken to the TV receiver via an r.f. modulator in the video recorder. This round-about way of signal transfer leads to reduced picture quality, and normally it also means that only one ancillary unit, in this case the video recorder, can be connected to the television receiver at any one time.

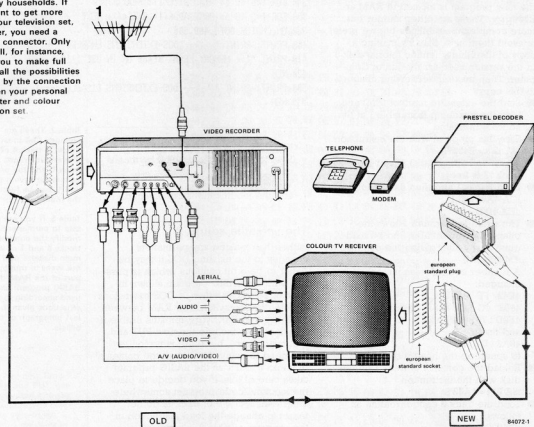

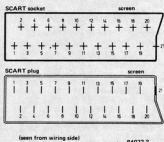
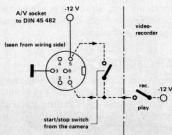

A/V connector

The quality of the transferred signal is improved by applying the audio and video signals *direct* to the relevant amplifier in the TV receiver or video recorder. This may be done via BNC (video) and phono (audio) connectors as shown in figure 1: four conductors are then required for recording and playback. Many modern TV sets are therefore fitted with a six-way A/V (audio/video) socket. Signals applied to the A/V socket should really be amplified by 6 dB (2x) and it is therefore advisable to use the A/V socket for playback only: recording can be accomplished direct from the aerial. To do this, pins 1 and 5 of the A/V socket must be interconnected. Signals are transferred between the TV receiver and the video recorder via a six-way cable, but even so, and in spite of the improved transfer quality, only one ancillary unit can be connected to the TV set at any one time.

SCART connector

The use of a number of ancillary units becomes possible only when SCART connectors are provided. An example of this is shown in figure 1 from which you can see that a colour TV receiver fitted with a SCART socket can be connected to the Prestel service and to a video recorder at the same time.

The pin connections of the A/V and SCART connectors are given in table 1, from which it becomes clear why the

A/V connector (DIN 45 842)

Pin	Recording	Playback
1	Input switching voltage 0 V	Input switching voltage +12 V
2	Video output Output impedance: 75 Ω Nominal output voltage: 1 V _{pp} into 75 Ω Colour sync signal level: 0.3 V	Video input Input impedance: 75 Ω Nominal input voltage: 1 V _{pp} Colour sync signal level: 0.3 V
3	Earth	Earth
4	Audio output (left-hand) Output impedance: <1 kΩ (above 20 Hz) Output signal level: 0.1...2.0 V into 10 kΩ	Audio input (left-hand) Input impedance: >10 kΩ (above 20 Hz) Input signal level: 0.1...2.0 V
5	Supply voltage input: +12 V	Supply voltage input: +12 V
6	Audio output (right-hand) Output impedance: <1 kΩ (above 20 Hz) Output signal level: 0.1...2.0 V into 10 kΩ	Audio input (right-hand) Input impedance: >10 kΩ (above 20 Hz) Input signal level: 0.1...2.0 V

SCART connector

Pin	Function	Level
1	Audio output (right-hand) or channel 2	0.5 V for output impedances ≤ 1 kΩ
2	Audio input (right-hand) or channel 2	0.5 V for input impedances ≥ 10 kΩ
3	Audio output (left-hand) or channel 1 or mono	0.5 V for output impedances ≤ 1 kΩ
4	Audio earth	
5	Blue earth	
6	Audio input (left-hand) or channel 1 or mono	0.5 V for input impedances ≥ 10 kΩ
7	Blue component	Difference between peak value and blanking signal level = 0.7 V; load impedance = 75 Ω; superimposed direct voltage = 0...2 V
8	Switching voltage: 0 = TV reception 1 = operation of associated units	0 = 0...2 V 1 = 9.5...12 V at input resistance of ≥ 10 kΩ and input capacitance of ≤ 2 nF
9	Green earth	
10	Not used	
11	Green component	Identical to 7
12	Not used	
13	Red earth	
14	Not used	
15	Red component	Identical to 7
16	Blanking signal 1 = blanking	0 = 0...0.4 V 1 = 1...3 V Load resistance = 75 Ω
17	Video earth	
18	Blanking signal earth	
19	Video output	Difference between peak white level and sync signal = 1 V; Output resistance = 75 Ω; Superimposed direct voltage = 0...2 V Synchronization signal only = 0.3 V _{pp}
20	Video input	Identical to 19
21	Housing screen and/or earth	Connected to chassis

Table 1. Pin connections of the A/V and SCART connectors.

SCART connectors have twenty-one pins. In contrast to the A/V facility, the recording and playback signals are not switched but are available simultaneously. Apart from the audio and video inputs and outputs, there are connections for the red, green, and blue signals, and the blanking signal. Together with the individual earth connections for all these lines, this accounts for the use of a total of sixteen pins.

Of the five remaining pins, one is used for switching from TV reception to operation of one of the ancillary units. With A/V connectors (and in some cases even with the SCART arrangement) this switching is carried out manually. Pin 21 is connected

to the housing of the SCART plug or socket and therefore also to the chassis (earth) of the TV receiver. Standard connections to pins 10, 12, and 14 have as yet not been agreed, although it appears that in due course 10 and 12 will be normalized as data connections.

SCART adapter

Proper normalization is, of course, not only a matter of co-ordinating the pin connections, but also one of matching the input and output levels of the TV receiver and the various associated units. For that reason we have included these levels in Table 1. The question remains, however:

Figure 2. The circuit of the SCART adapter consists of the buffer stages for the video and blanking signals, and the matching stages for the red, green, and blue signals. The output levels are in accordance with those given in table 1.

2

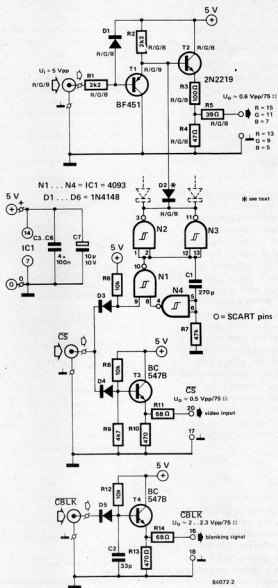

84072-2

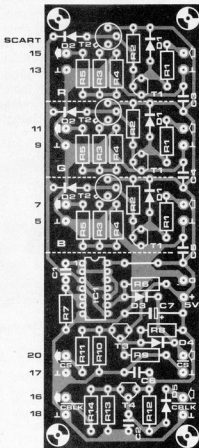
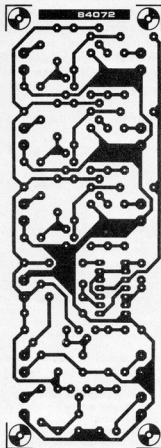

Parts list

Resistors:

R1, R2 = $2k\Omega$
 R3 = 100Ω
 R4 = 47Ω
 R5 = 39Ω
 R6, R8, R12 = $10k$
 R7 = $47k$
 R9 = $4k7$
 R10, R13 = 470Ω
 R11, R14 = 68Ω

Capacitors:

C1 = $270p$
 C2 = $33p$
 C3 ... C6 = $100n$
 C7 = $10\mu/10V$

Semiconductors:

D1, D2 = 1N4148*
 T1 = BF451*
 T2 = 2N2219*
 D3 ... D5 = 1N4148
 T3, T4 = BC547B
 IC1 = 4093

Miscellaneous:

10 BNC sockets
 Screened case
 Printed circuit 84072

* one of each required for red, green, and blue respectively

how can you be sure that the output level of your personal computer matches the sensitivity of the RGB inputs of the TV set? Well, we have designed a means of answering that!

The sensitivity of the SCART inputs is too high for signals at TTL or CMOS levels, such as, for instance, the outputs of home computers. Moreover, the input impedance of 75Ω is too low. We have designed matching circuits to counter these differences and accommodated them all on one printed circuit.

With reference to figure 2, only simple buffer stages (T3 and T4) are needed to keep the level of the video and blanking signals within acceptable limits. These stages should preferably be fed from open-collector outputs (collector resistance about 330Ω).

The red, green, and blue signals should be treated rather more carefully. Leading as well as trailing edges of the rectangular signals must be transferred without any delay to prevent colour distortion occurring. The stage for processing these signals (T1 and T2) is therefore more extensive than the buffers. The output voltage is maintained at a level just under the nominal sensitivity of the TV set ($0.7V_{pp}$) so that the receiver cannot be overloaded.

Red, green, and blue signals at a frequency lower than the line frequency must be switched off periodically to allow the input capacitor in the TV receiver to discharge. This switching is arranged by IC1 which is connected to the colour processing stage via diodes D2 (one for each colour). If the colour signals are obtained via the 'analytical video display' (see *Elektron*, May 1984, page 5-31), IC1 is definitely necessary. If, however, there are no coupling capacitors in the TV set, IC1 may be omitted.

All stages can be accommodated without any problems on the printed-circuit board shown in figure 3. All signals are fed to the printed circuit by screened cables. The earth connections are soldered to the terminals adjacent to those for the input or output signals: each signal line has its own individual earth connection!

It is recommended to fit the printed circuit in an earthed box and to use BNC connectors for the inputs and outputs. The supply voltage of 5 V may be applied via an appropriate low-voltage plug-and-socket arrangement.

It may well be that by using the circuit and relevant control signals you will discover numerous new aspects in your television receiver. Good luck with the experiments!

Figure 3. Copper track and component layout of the printed circuit for the SCART adapter. Each (screened) signal line has a separate earth connection for which corresponding terminals have been provided.

Ready-made equipment cases are often quite expensive and sometimes impossible to get in the dimensions required. In such instances many electronics hobbyists design and produce their own cases. As they often have neither the skill nor the tools to work with perspex or sheet iron, they invariably turn to aluminium, which is light, easy to work, and looks good. The only troubles with aluminium are that it does not look so good when it oxidizes and that it is easily scratched. The remedy for these troubles need not always be paint-spraying: anodizing is a worthwhile and attractive alternative.

anodizing aluminium

in your home workshop

Anodizing is a process whereby a hard, non-corroding oxide film is deposited onto the aluminium. This film is harder and far more scratch-resistant than the aluminium itself; it also protects against fingerprints which can be a real nuisance.

Ingredients and equipment required:

caustic soda lye (1 : 10)
nitric acid
sulphuric acid solution (1 : 7)
distilled water
a piece of lead
a suitable tank
a variable mains power supply or heavy-duty battery

Because of the sulphuric acid, the tank must be of glass or plastic, and it must, of course, be large enough for your purposes. A photographic developing tray

may, for instance, be suitable; alternatives are a large plastic bottle or container with the top cut off, domestic glass basins, plastic washing-up bowls, and so on. An electric direct current of 1.5 ... 2.5 A for every 100 square centimetres (16 in²) of aluminium should be available. This is most easily obtained from a variable power supply, but a suitable heavy-duty battery and appropriate variable resistor to keep the current within the limits stated may also be used.

For the electrolysis the aluminium is made the anode, while the cathode is formed by the piece of lead. The surface areas of the aluminium and lead should be roughly equal.

Obtaining the chemicals should present no problems, although you will not be able to buy them in the concentrations required. The caustic soda lye is prepared by stirring 10 grammes of sodium hydroxide in 100 ml of distilled water; this solution cannot be stored in glass vessels, only in plastic ones. The concentration of the nitric acid is not critical: add one part to about nine parts of distilled water.

Preparation of the sulphuric acid solution is a little more complicated although the following formula should be a great help. $m_1 = m_2 (x\% - y\%) / y\%$, where m_1 = distilled water by weight, m_2 = sulphuric acid by weight, $x\%$ = concentration of sulphuric acid, $y\%$ = concentration of required sulphuric acid solution

If, for instance, a 1 : 7 (say, 15%) sulphuric acid solution is required, and 250 grammes of sulphuric acid in a 50% concentration is available, the relevant amount of distilled water by weight is 583 grammes.

Warning! Always add acids to water, never water to acids.

Always be careful when working with these chemicals. Ensure good ventilation of the working space, do not smoke (because of the production of highly combustible oxy-hydrogen gas), do not wear

J. Laakmann

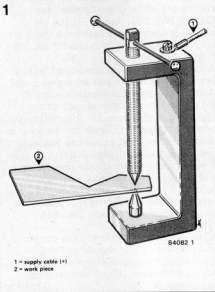

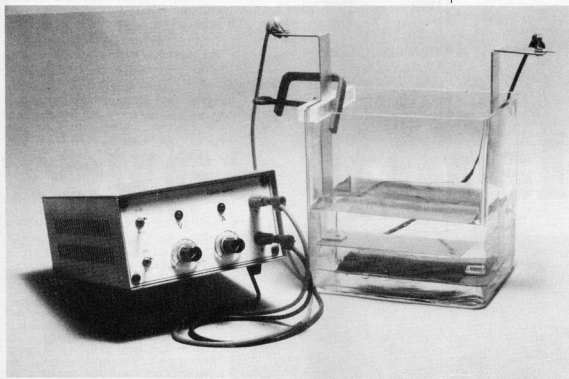

your best clothes, and do use rubber or plastic gloves and some form of effective eye protection.

Processing

First smooth the aluminium with grade 400 wet-and-dry emery paper: take care not to overheat the aluminium as this may cause blemishes during the anodizing. Next, immerse the aluminium for about ten minutes in the caustic soda lye (at room temperature) to remove all grease.

Decolouration often occurs, but this disappears when the aluminium is etched in a 1 : 10 nitric acid solution.

Only now can the actual electrolysis take place. Suspend the sheet of lead, connected to the negative terminal of the power supply or battery, in the sulphuric acid solution. The aluminium should be connected to the positive terminal via a strip or piece of aluminium: other materials may dissolve during the processing. A suitable means would be an aluminium C-clamp as used in model building in which a screwthread is cut as shown in figure 1. The supply cable is terminated into a soldering tag which is fastened to the clamp by a screw driven into the freshly cut thread. The aluminium work piece or sheet must be slightly larger than required because no anodizing can take place under the clamp screw.

At a solution temperature of 16 . . . 20°C (inspect frequently), the processing will take about one hour. The solution may have to be cooled now and then, while an occasional stir is also advisable. When the

current drops, the electrolysis may be terminated. The aluminium work piece should be thoroughly rinsed in distilled water after each of the operations described.

Finally, the aluminium must be condensed in boiling water for about fifteen minutes. In this, the pores of the oxide film close to some extent and the whole work piece hardens.

Protection of the environment

When the chemicals are no longer required, they should be neutralized before they are flushed away. Nitric and sulphuric acids may be neutralized with the caustic soda lye. You may not have enough left of this and it is then necessary to make up some more. The pH value may be checked with a pH meter or litmus paper (which turns red in acids and blue in alkalis). It is also possible to use indicators such as phenolphthalein ($C_{20}H_{14}O_4$) which is colourless in acids but turns red in alkalis, or methyl orange ($C_{14}H_{14}N_3NaO_3S$) which is red in acids and gradually changes through orange to a full yellow colour in alkalis. ■

Most incandescent bulbs have an estimated lifespan of about a thousand hours of brightness. The actual time when the bulb blows is determined by the weakest link — the thinnest part of the filament. The most obvious way of increasing the filaments lifespan is to concentrate on the weak part, and in particular by limiting the peak current at switch-on as this is what causes the filament to burn out. Two versions of this zero-crossing switch have been designed and both are easily built into existing installations.

lamp saver

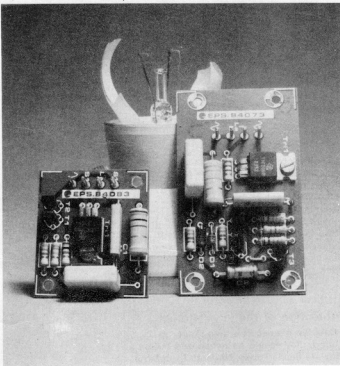

increases the longevity of incandescent bulbs by switching them on at the zero-crossing point of the mains

About this time of the year home owners are forced to start thinking about making certain preparations for the winter, such as ordering fuel for the central heating. At the same time most people are likely to consider how to economise, and not only on the central heating bill. Lower wattage light bulbs are then used and insulating products are bought. More significant savings can be made by changing your habits, by drawing curtains sooner, turning the central heating down one or two degrees, by not leaving doors open unnecessarily and so on. These economy measures do not even involve any additional expenditure.

Under the heading of 'energy conscious habits' is the idea of switching off lights in the room you are just about to leave. This certainly saves some electricity but it is not without fault. Continuously switching an incandescent lamp on and off will shorten its lifespan quite considerably.

The filament in an incandescent bulb has a lower cold resistance than when it is warm, so it acts as a resistor with a positive temperature coefficient (PTC). The peak current at switch-on will therefore be much higher than the maximum continuous current, especially if the light is switched on when the voltage is near its maximum value (see figure 1). In order to understand what this high current does to the lamp we must realise that the filament is not smooth and even but rather it is very rough. The switch-on peak will therefore cause hot spots to appear at the points where the filament is thinnest. These points suffer from wear and tear which eventually leads to one of them burning through, usually immediately upon switch-on.

The lifespan of the incandescent lamp is determined by the weakest point in the filament. We can protect this weak spot by switching on the lamp at the most favourable moment, namely at the zero-crossing point of the mains. During the first quarter cycle of the mains the current through the filament will heat it enough so that when the voltage is first at its maximum the resistance will be high enough to keep the current, and therefore the temperature of the hot spot, fairly low (see figure 2). In this way the lifespan of the lamp is improved.

The requirements

What we want is a circuit that will detect the zero-crossing of the mains and switch on the appropriate lamp(s) at this time. It should also be easy to fit into existing installations without having to run extra wires or knock holes in the masonry. Finally the cost should be low to enable the investment to be earned back quickly. The circuit described here meets these demands and is a particularly attractive proposition if you use expensive bulbs. Another interesting application of the lamp saver is in cases where the lamp is difficult to reach for replacement. Let there be any misunderstanding, let us state clearly that this circuit is only useful for incandescent lamps. It cannot extend the lifespan of fluorescent lights at all.

The two versions

Building this lamp saver circuit into existing installations is simplified by the fact that we have developed two different versions. Version 1 is a circuit that must be fitted to an existing lamp but no changes to the wiring are required. The wires that were connected to the lamp fitting are now connected to the circuit instead and the fitting is linked to the appropriate points on the printed circuit board.

Version 2 is somewhat smaller as it is primarily intended for mounting behind the light switch in the wall. If there is not enough space for this the original switch can be replaced by a miniature 240 V one as the current passing through it is very small. Version 2 is not suitable for use with two-way switches; version 1 must be used in this case.

The circuits

Moving on to the circuits we will now begin with version 1. Technically speaking this is the more interesting of the pair. Various sections can be seen in the circuit diagram of figure 3: a d.c. supply for the gate pulses (R1, C1, C2, D1, D2), a zero-crossing detector (R2, R3, T1, T2) and, of course, a triac with R7 and C3 to suppress excessive voltage peaks. When the switch is closed the mains voltage is applied across the voltage divider consisting of R2 and R3. As long as the voltage at the junction of R2 and R3 does not exceed 0.7 V transistors T1 and T2 are switched off. In practice this means that neither T1 nor T2 will conduct when the voltage is within the range of about -8 V to $+8\text{ V}$. A 'window' is thus formed around the zero-crossing point of the mains. If the instantaneous mains voltage is greater than $+8\text{ V}$ T2 will conduct, whereas when the mains value is more negative than -8 V T1 will conduct.

As soon as the mains voltage is applied to the circuit capacitor C2 is slowly charged via C1, R1 and D2 up to a maximum of 10 V (defined by D1). After a few periods C2 will be charged enough to provide a trigger current for the triac. This is supplied via transistor T3, but only around the zero-crossing point. At all other times T3 is kept off through the action of T1 or T2 (depending on the phase). Summing this up: T1...T3 ensure that the triac can only conduct at around the zero-crossing point. The gate pulses are delayed a few periods after switch-on (by C2 and everything to the right of it) to allow transistors T1 and T2 to get into their rhythm.

Version 2 of the circuit is slightly simpler than version 1, at the price of a few concessions. The switching window is set up in the same way (with R3, R4, T1 and T2) but the supply for the gate of the triac is changed. In this case the gate current is supplied via C2 and R2. When on/off switch S1 is closed the triac will never be triggered so the lamp remains off. When S1 is open, on the other hand the triac can

1

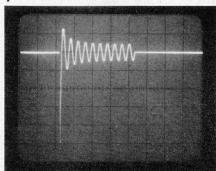

2

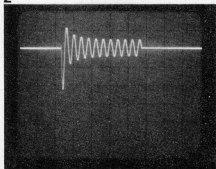

lamp saver

Figure 1. When an incandescent lamp is switched on at the peak voltage level the peak current is about ten times as high as the maximum constant value in normal use. The lamp in question here is an expensive spotlight with built-in reflector.

Figure 2. In contrast to the situation in figure 1, the lamp switched on via the lamp saver at about the mains zero-crossing point only has to handle a current five times as high as the maximum nominal value. This halving of the peak current corresponds to a reduction of the maximum power by a factor of four.

be triggered but only within the window defined by R3, R4, T1 and T2. In order for this circuit to work it is essential that the mains is always present and that the lamp, La1, is connected in series with it. If the circuit were connected straight across the mains and this just happened to be at its maximum value the triac would immediately be triggered via C2 and R2 even before T1 or T2 starts conducting. In that way the lamp would switch on when the mains voltage is at its maximum value, which is exactly what we wanted to prevent.

Figure 3. Version 1 of the lamp saver should be built into the light fitting. The light switch, S1, then switches the whole circuit on and off.

3

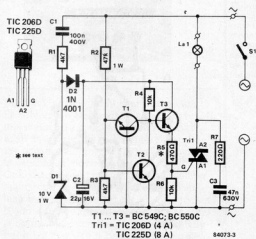

A subtle difference between this version and the first one is that in this case T2 is a PNP transistor. This is necessary because the gate of the triac is fed an a.c. rather than d.c. signal. The gate current therefore alternates between negative and positive so a PNP transistor is needed to conduct the negative gate current.

The disadvantage of this version of the circuit is that it must always have a mains supply connected to it. Naturally this means that there will always be a certain amount of current consumed but in terms of the normal values of current we talk about for mains-powered equipment this is negligible.

Construction and installation

Building either version of the lamp saver is child's play using one of the printed circuit boards shown here. Which version is used depends on your own individual requirements. If the light in question is controlled by more than one switch then version 1 must be used. As we have already

said, this board is mounted into the actual light fitting. All the necessary constructional details can be gleaned from figure 5 and figure 6.

Space is saved by not mounting the triacs on a heatsink but this means that the maximum power that can be handled is a bit limited. This is dependent upon the way in which the board is mounted, particularly as regards the amount of cooling air that flows around the triac. The circuit can handle 300 W in any case, and this is quite sufficient for the vast majority of domestic applications. If, however, this is found to be insufficient the triac can be cooled by mounting it on an aluminium bracket. This will have to be made especially to suit the space available.

Another possibility is to use a more powerful triac, 8 A instead of 4 A, in which case it may be necessary to reduce the value of resistor R5 to 330 Ω (in version 1). The triac is then always triggered by a positive gate current, irrespective of the phase. The TIC 225D's greater gate current

Figure 4. Version 2 of the circuit is slightly simpler than version 1. Correct operation is ensured by connecting the circuit continuously to the mains. If space is at a premium a small (low current) 240 V switch may be used.

4

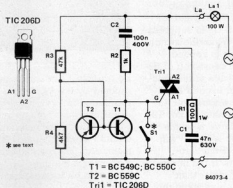
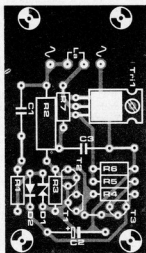
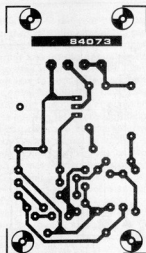

Figure 5. The usual care is required when fitting the components to the printed circuit board (version 1 is shown here) but no special precautions are needed.

5



Parts list

— Version 1

Resistors:

R1, R3 = 4k7
R2 = 47 k
R4, R6 = 10 k
R5* = 470 Ω
R7 = 220 Ω

Capacitors:

C1 = 100 n/400 V
C2 = 22 μ /16 V
C3 = 47 n/630 V

Semiconductors:

D1 = 10 V/1 W zener
D2 = 1N4001
T1 . . . T3 = BC 549C,
BC 550C
Tn1 = triac, such as
TIC 206D (4 A) or
TIC 225D (8 A)

* — see text

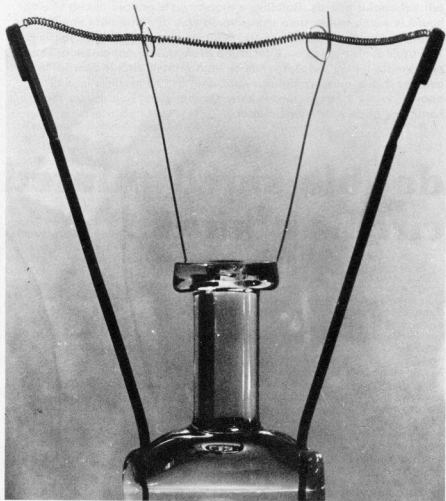

lamp saver

Parts list

— Version 2

Resistors:

R1 = 100 Ω /1 W
 R2 = 1 k
 R3 = 47 k
 R4 = 4k7

Capacitors:

C1 = 47 n/630 V
 C2 = 100 n/400 V

Semiconductors:

T1, T2 = BC 559C,
 BC 560C
 Tri1 = triac, such as
 TIC206D (4 A) or
 TIC 225D (8 A)

Miscellaneous:

S1* = switch

* = see text

6

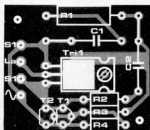
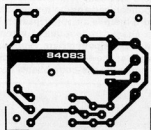

Figure 6. As in version 1 of the lamp saver, the triac in version 2 is not mounted on a heatsink. If the power handling capabilities are found to be too limited Tri1 may be mounted on an aluminium bracket.

requirement has the result that it is only triggered during positive half-cycles so the lamp will be seen to flicker. It is difficult to give any specific advice about installing the lamp saver as this depends on the individual application. An alternative to mounting version 1 in the light fitting is to fit it into a small case. In this way the circuit can also be used with lamps that are plugged into a mains wall socket. For the circuit to operate correctly in this application it is essential that the switch is connected between the wall socket and the lamp saver.

Version 2 of the circuit is small enough to fit behind the wall switch in most cases. If this is not so a smaller switch may be used as it only has to be able to handle the (small) gate current. Whatever switch is used must, however, be rated at 240 V. One last piece of advice: when installing this circuit be sure to remove the mains fuse beforehand and put it in your pocket. If you don't do this some 'helpful' person is bound to notice the fuse and helpfully put it back where it belongs. This same person is likely to be quite shocked at your comments!



Few electronic hobbyists today have any qualms about making printed circuit boards. Building a project on a printed circuit board is much easier than using Veroboard or something similar, wiring is kept to a minimum and fault finding is greatly simplified. The project also takes on a far more professional appearance. These plus points make it worth while to etch printed circuit boards. In general this is quite straightforward and, as the process is well known, we will not go into it here. Double-sided boards, on the other hand, are quite a different matter.

double-sided printed circuit boards

how to make
them yourself

Double-sided printed circuit boards are quite commonly used in electronics, particularly in HF, where one side acts as an earth plane, or in circuits where a large number of connections between various components have to be made in a relatively small area (such as computers).

Making these boards is something hobbyists are happy to leave to professionals and, indeed, without the right facilities it can be very tricky. One of the difficulties with making double-sided printed circuit boards is that the copper tracks on both sides must be correctly aligned. This is dependent on the process used but in general terms what it involves is preparing one side of the board first, by developing it if photo-etching is used, or applying transfers or etch resist. Then a few holes are drilled, the most common being the corner ones. The second side of the board can then be prepared in the same way as the first and using the holes to facilitate alignment. Another possibility is to etch two printed circuit boards corresponding to the two sides of a double-sided design. These are

then drilled and strong glue is applied to the reverse side of each board. The boards are then carefully aligned with each other, by inserting pins in some of the holes, for instance, and stuck together. When the glue sets the board is ready for use.

So far this is nothing any hobbyist could not handle but after the board is etched Murphy strikes with a vengeance. Professional double-sided boards (like those supplied by Elektor through the EPS) have 'through-plated' holes so that they connect the copper on both sides of the board. The equipment used to plate the holes is generally only found in businesses or schools so unless you have the right connections an alternative will have to be found.

The most simple alternative is shown in figure 1. This simply involves soldering the component leads on both sides of the board if there is a copper pad on both sides. Great care is required when doing this if the components are very heat-sensitive as the soldering iron is closer than normal to the components and for

Figure 1. The easiest way of connecting the two sides of the printed circuit board is by soldering the component leads at both sides.

1

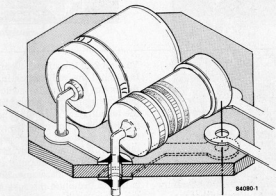

twice as long as usual. Use a heat shunt if possible.

Sometimes it may not be feasible to solder components on both sides or there may not be a component where the two sides of the board are to be linked. This brings us to figure 2a and 2b. Pins for insertion into printed circuit boards are available in two sizes, as figure 2a shows. These can be inserted into the board and (if necessary) soldered at both sides to provide a more professional appearance than component leads (or off-cuts of same). An altogether better solution is indicated in figure 2b, in the form of through-PCB pins. As the drawing shows, these are simply inserted into the hole and soldered at both sides to provide a good connection.

It is quite feasible to make double-sided printed circuit boards using the methods outlined, or, as is more likely, a combination of them, but in the case of complicated circuits they would almost certainly demand a redesign of the printed circuit board. There is, however, an alternative to all these methods that does not require any redesign. This is shown in figure 3. A hollow through-PCB pin is inserted into the hole drilled for it and is soldered at both sides. In order to prevent the hole in the insert from filling with solder it is necessary to thread a length of enamelled copper wire (about 0.8 mm in diameter — SWG 20) through it during soldering. When this is removed the result has the same effect as a through-plated hole. The insert is prevented from continually falling out of the hole during soldering by first widening its narrow end above the diameter of the hole with a nail or something similar. Unfortunately this 'wonder insert' has one disadvantage — it is not yet freely available in the U.K., as it is on the Continent, but we hope this situation will soon improve.

2a

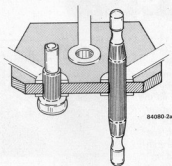

double-sided
printed circuit boards

Figure 2a. Pins are available in two sizes for inserting into PCBs. A special insertion tool is needed to do this.

2b

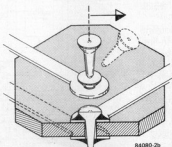

Figure 2b. Another way of connecting the two sides of a board is to insert this sort of through-PCB pin and solder it at both sides.

3

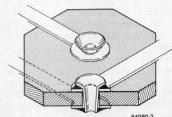
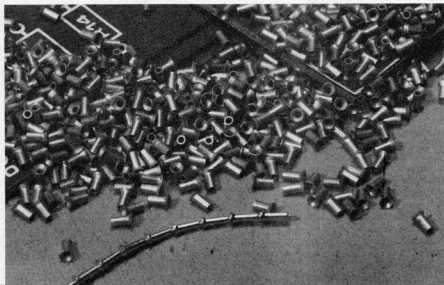

Figure 3. The next best thing to through-plating the holes is this insert. Using this it is possible to make very good double-sided printed circuit boards without needing any special equipment.



applicator

2716 + 6116 = 4820Z

Memory IC type MK4820Z from Mostek is compatible both as regards pinout and functions with the byte-wide CMOS RAM 6116 as well as the type 2716 EPROM. This may appear to be a contradiction, but a look at the photograph (where you can see two lithium batteries) will make matters a little clearer: the 4820Z is, in principle, nothing but a battery-buffered RAM. In contrast to earlier attempts at such a device, as for instance the IPROM, the batteries as well as the voltage control are now contained in the same housing as the chip. Except for its height, which is slightly greater than normal because of the batteries, the housing is of the standard 24-way dual-in-line type. The 4820Z can therefore be used as a direct replacement of a 2716 or a 6116 to offer the following advantages:

- high storage reliability due to the integrated, secure voltage switching;
- data retention in the absence of power;
- data security provided by automatic write protection during power failure;
- long data retention period (≥ 10 years) due to HCMOS technology.

At the moment, because of its price of around E35, the 4820Z is too expensive to be used as a simple programmable EPROM substitute, but there are applications where the price is justified. These will be discussed later in this article.

Technical characteristics

The pinout of the 4820Z is shown in figure 1: except for pins 18, 20, and 21, it is in accordance with that of the 2716 or 6116. Pin 18 of the 2716 is designated \overline{CE} (Chip Enable); that of the 6116 is \overline{CS} (Chip Select), and in the 4820Z it is \overline{E} (Enable). In prac-

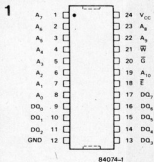
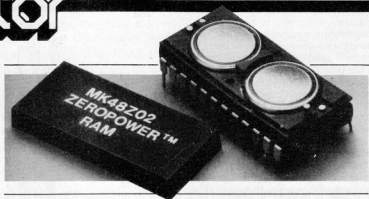

Figure 1. Pinout of the MK4820Z.



2

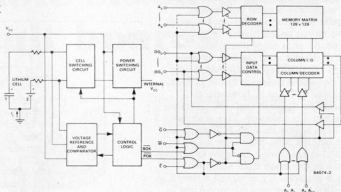

Figure 2. The functions of the RAM/EPROM can be easily recognized here.

tice, these differences are meaningless. In the same way, 'forget' the designation \overline{G} at pin 20 of the 4820Z: this pin is the \overline{OE} (Output Enable) terminal exactly as in the 2716 and 6116. Pin 21 of the 2716 carries the programming voltage: after programming this terminal should be made logic 1. In the 6116 and 4820Z, this pin is the Write Enable terminal (abbreviated to \overline{WE} or \overline{W}): it should be logic 0 before any data can be written into the store.

In the block diagram of figure 2, the typical structure of the actual memory with its memory matrix, row and column decoders, and so on, is easily recognized at the right. At the left are the voltage switching circuits and the lithium batteries. The comparator compares the voltage at pin 24 (V_{CC}) with the internally generated reference voltage.

The normal supply voltage may lie between 4.75 V and 5.5 V (maximum). Below 4.75 V there are two further important levels: 4.5 V and 3.0 V. If the supply voltage drops below 4.5 V, the data bus will go into the high-ohmic state (three state) independent of the levels on terminals \overline{E} (pin 18) or \overline{W} (pin 21). This prevents the data in memory being affected by the on and off switching of the supply voltage. When V_{CC} drops below 3.0 V, it is

switched off and the lithium batteries provide the required power.

When the external supply voltage lies between 4.5 V and 4.75 V, the lithium batteries are tested. If the voltage of one of them is below 2.0 V, a flag is set. This flag inhibits the first write cycle after the supply voltage has been switched on. It is therefore easy to ascertain by means of a software loop whether the lithium batteries are in good working order:

- read the contents 'N' of an arbitrary memory location 'X' and write these in a different position in the system;
- load a value different from 'N' into location 'X';
- check that the new value is stored correctly;
- reload 'N' into 'X'.

This routine must, of course, be carried out as a first write operation when the 4820Z is used after a power-on reset.

The timing diagrams of figures 3 and 4, as well as table 1, contain the detailed operating conditions of the 4820Z. The write-cycle time, t_{WC} , in the 4820Z is equal to the access time (read-cycle time), t_{RC} . The device is available with a read/write cycle time of 150 ns, or 200 ns, or 250 ns, which is shown in a suffix to the type number: 15, 20, or 25. For instance, an MK4820Z-20 is the version

telephone amplifier

Modern technology has produced fast transport and centralised industry. A somewhat less desirable side-effect is that close relations have tended to become distant relations. Instead of gathering around the fire as in the 'good old days', we tend to gather around the telephone.

This means of communication suffers, however, from one major flaw: Ma Bell never intended it as a vital link between whole families. The system itself and all the legal restrictions involved with it are geared to private conversations between two individuals. The solution to the problem? A loudspeaking telephone.

Figure 1. Block diagram of the telephone booster. The signal is picked up by a coil, since a direct connection into the telephone lines is not permitted. The booster itself consists of two sections, one mounted as close as possible to the phone and the other — much larger — section placed in any convenient spot.

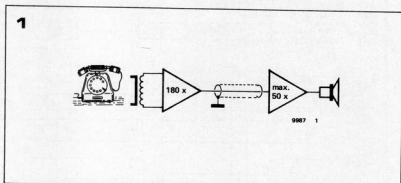

The circuit described here will pick up the telephone conversation and reproduce it via a loudspeaker, so that several people can listen in.

This is only possible, of course, if the electrical signals from the telephone are first picked up in some way. Since the Post Office, understandably, does not like people tampering with their wiring, some kind of indirect coupling is required. The most common method is to use a so-called telephone pick-up coil.

This operates on a very simple principle: in every telephone there is a transformer which is wound and wired in a cunning way in order to route the incoming signal from the telephone line to the earpiece, and at the same time feed the microphone signal onto the line. In effect, it forms a kind of splitter for audio signals, with good coupling from line to earpiece and from microphone to line, but with poor coupling between the microphone and earpiece to avoid acoustic feedback.

All transformers have a stray field, and this one is no exception. If a suitable coil is placed in this field, it will 'pick up' the audio signals. Logically enough, a device of this kind is called a pick-up coil. The electrical signal delivered by the coil is extremely small, so that a lot of gain is required in the following amplifier stages. As shown in the block diagram (figure 1), the amplifier described here consists of two sections. The first section has a gain of 180 (45 dB). It can be connected via almost any length of single-core screened cable

to the second section, which has a gain of up to 50 (34 dB). This second stage drives the loudspeaker.

The advantage of cutting the circuit in two is that the first stage can be mounted quite near to the pick-up coil, minimising the amount of hum and interference picked up by the connecting wires. The bulk of the circuit, including loudspeaker and power supply, can be mounted at any suitable remote position.

Up to 50 m (160 ft) of screened cable can be used between the two stations — more than enough for any practical application we can imagine. The first section has no power supply of its own: it is powered from the main section via the connecting cable.

The circuit

The complete circuit is shown in figure 2: figure 2a is the first stage, which is mounted near the pick-up coil; figures 2b and 2c are the second stage and the power supply, respectively.

The pick-up coil, L1, is a normal miniature choke and the value is not particularly critical. It is sometimes possible to obtain coils designed specifically for this purpose, mounted in a plastic capsule with a suction cup at one end. L1 and C1 together form a resonant circuit, but this is so heavily damped by R1 and the input impedance of T1 that the resonant peak is hardly noticeable — the main effect is to limit the bandwidth to a useful value.

The first stage would be a two-transistor

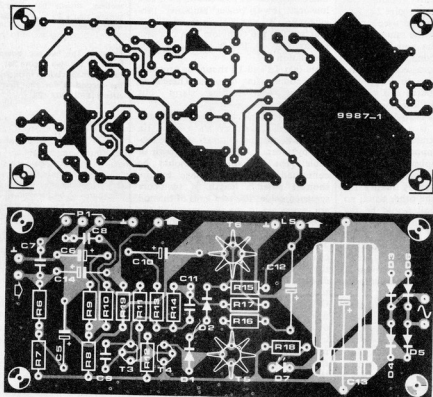
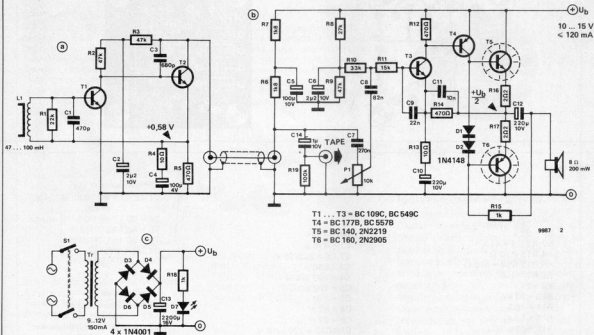

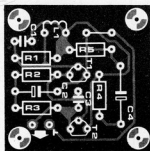
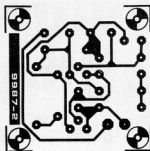

Parts list

Resistors:

R1 = 22 k
 R2, R3, R9 = 47 k
 R4, R13 = 10 Ω
 R5, R12, R14 = 470 Ω
 R6, R7 = 1k Ω
 R8 = 27 k
 R10 = 33 k
 R11 = 15 k
 R15 = 1 k Ω
 R16, R17 = 2 Ω
 R18 = 1 k
 R19 = 100 k
 P1 = 10 k log.

Capacitors:

C1 = 470 p
 C2, C6 = 2 μ /10 V
 C3 = 680 p
 C4 = 100 μ /4 V
 C5 = 100 μ /10 V
 C7 = 270 n
 C8 = 82 n
 C9 = 22 n
 C10, C12 = 220 μ /10 V
 C11 = 10 n
 C13 = 2200 μ /16 V
 C14 = 1 μ /10 V

Semiconductors:

T1, T2, T3 = BC 109C, BC 549C or equ.
 T4 = BC 177B, BC 577B or equ.
 T5 = BC 140, 2N2219
 T6 = BC 160, 2N2905
 D1, D2 = 1N4148
 D3 ... D6 = 1N4001
 D7 = LED

Miscellaneous:

L1 = miniature choke, 47 ... 100 mH, see text
 LS = 8 Ω /200 mW loudspeaker
 Tr = 9 ... 12 V/150 mA mains transformer
 S1 = DPDT mains switch

amplifier with a gain of 180, if T2 had a 1k Ω collector resistor. Following the connecting cable, this resistor can indeed be located: R6 in figure 2b. This little trick, which was also used in the Preco, saves one wire: the same cable is used to feed the audio signal from the first section to the second and to supply power from the second section to the first. The output of the first section is basically a current source and can be loaded by a relatively low impedance, permitting the use of a fairly long cable. The second section is a 'bare-bones' design: only four transistors and a handful of other components are used in this little power amplifier. There is no quiescent current adjustment - that would be an unnecessary luxury for this application. On the other hand, no quiescent current at all would be the other extreme - the maximum gain would be lower. P1 is the volume control. A tape output is also provided, although it should be noted that - strictly speaking - the other party should be notified if the conversation is to be recorded.

The power supply (figure 2c) is straightforward. The only 'luxury' there is the LED, D7.

Construction and use

Printed circuit board designs for the two sections are shown in figure 3. The main (figure 3b) contains both the second

section and the power supply. It is perhaps interesting to note that this board can also be used on its own as a low-cost, low-fi 'power' amplifier, provided R6, R7 and C5 are omitted. For that matter, the complete unit can also be used as a 'low-fi' public address installation...

Note that T5 and T6 should be provided with cooling fins or clips. There's no harm in them running 'warm', but they're not supposed to get 'hot'.

The two sections can each be mounted in their own case (even a tobacco tin will do for the first stage!) and connected by means of the desired length of cable. The pick-up coil should be connected to the first stage by the shortest possible length of twin-core screened cable: the two ends of the coil are connected to the two cores and the screening is connected to supply common.

The best position for the pick-up coil can be found by trial and error. When the handset is lifted off the hook, a dialling tone is obtained (if no dialling tone is heard, complain to the Post Office, not us) and the pick-up coil can now be moved, twisted and turned all over the telephone (not the handset) until this tone is reproduced at maximum strength by the loudspeaker. Note that both the position of the coil and the direction in which it is pointing will influence the 'reception'. Once the best position and location have been found, the coil can be fixed in position. **M**

Figure 2. The complete circuit. Figure 2a is the first section, which is connected by means of single-core screened cable to the second section, shown in figure 2b. The power supply, figure 2c, can also be mounted in the main station.

Figure 3. The two p.c. boards required. The larger of the two (figure 3a), EPS 9987 - 1, is for the main station including power supply; the second is for the first section of the circuit (EPS 9987 - 2).

BATTERY CHARGER

A solid state, thyristorised charger with several in-built safety measures has been put on the market by Advance Industries under the trade name "Globe" battery charger. The manufacturers claim the charger to be foolproof against undervoltage and overvoltage, short circuit and reverse battery connection. The automatic battery chargers are available in different models from 6V to 36V.



More details can be obtained from: Advance Industries, Tinwala Building, Tribhuvan Road, Bombay—400 004.

POWER AMPLIFIER

A high speed, high power operational amplifier is offered by Apex Microtech. The industry standard PA84 is now offered in an enhanced, fast settling version PA84 S where application response to a step input is critical. With the fast settling time, the PA84 S is ideal for such applications as input multiplexed data distribution systems or voltage conversion utilising a current output DAC.

For further information contact: Elmatronic Devices, 14, Hanuman Terrace Lamington Road, Bombay—400 007.

LEAKAGE METERS

For electrolytic capacitors manufacturing units, Spectron leakage current meter is an essential instrument which can measure leakage current of the capacitors in the ranges of 1 microamp to 10 milliamps. The bias voltage can be continuously adjusted from zero to 600 volts.



For details contact: Spectron sales and service pvt. Ltd., 63, Bharatkunj no. 2, Erandvane, Pune—411 038.

SWITCHES

Switches in international design, called "Intel" series, especially for electronic applications, have been introduced by Indian Engineering Company. The series range consists of miniature toggle switches rated for 3 amps, 250V A.C. or 28V D.C. Available in four types with push buttons.

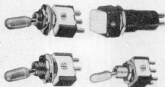

For further details contact: Indian Engineering Company, 132A, Dr. Annie Besant Road, Post Box no. 16551, Worli Naka, Bombay—400 018.

THUMBWHEEL SWITCHES

"Comtech T-21" series for miniature thumbwheel switches have been developed by M/S Component Technique for a variety of applications such as preset devices in digital systems, as divider network switches or selector switches. A number of basic switch modules can be stacked together. The thumbwheel is marked prominently with white legend on black background.



For further details, contact: Component Technique, 8, Orion, L.P. Road, Andheri west, Bombay—400 058.

HERMETIC CONNECTORS

For providing true hermetic sealing at the critical electronic/environment interface, ITT Cannon has developed the compression glass-sealed "U" sub-miniature series which are available in three sizes with bayonet coupling and threaded coupling. For more information on the light weight, vibration and shock resistant connectors,



write to: Jost's Engineering Company, 60, Sir P.M. Road, Bombay—400 001.

DIGITAL NUMERAL PRINTER

IRA have introduced Digiprint—18. Digital Numeral Printer, which has a CMOS interface and accepts serial/parallel BCD inputs. It is claimed to be immune to electrical disturbances. 6, 12 or 18 column printers can be interfaced depending on the need. Printing by employing external remote signal is possible. Applications include permanent record for off-line processing, data collection, data-logging and weighing scales.



For more information, contact: Instrument Research Associates Pvt. Ltd, P.B.No. 2304, No.79/1-2, Magadi Road, Bangalore-560 023.

SEQUENTIAL CONTROLLER

Sbaj electronics have introduced a new model of auto reverse sequential controller, taking 1,000 watts load/channel, are in sequential machine operation, light decoration exhibition, discotheques, orchestra and theatres.



For further information: Sbaj electronics, 19, Mother Gift Building, Grant Road, Bombay—400 007.

LOGIC TRAINERS

ALFA logic trainers are designed to combine theory and practice, these logic trainers are suitable for learning, designing and testing of digital logic circuits.

The logic trainers are claimed to be fully self-contained with built-in solderless breadboard of excellent quality, suitable IC regulated power supply, bounceless data switches and buffered LED monitors. Other built-in features are a logic probe, digital pulser and pulse detector, which can also be used independently.

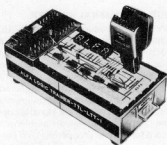

For further information, write to:
Alfa products company
FF-11, Bajaj House, 97 Nehru Place
New Delhi-110 019.

CORDLESS BELL

'Anushya' has introduced a electronic cordless call bell system which works on remote control technique using super high frequency and unique pulse coding. It is claimed that the system has no interference with other broadcast systems.

The cordless call bell system finds applications as domestic call bell, office call bell, security alarm and it can also be used for remote controlled ON/OFF operation of electrical appliances.

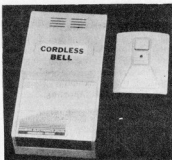

For further information, write to:
M/s Anushya Electronics Pvt. Ltd.
1-1-714/C/3, Gandhinagar,
Hyderabad-500 380 (A.P.)

RECTIFIERS IN TO-3

Semiconductors Ltd. have now developed a new series of Full Wave Rectifiers in the TO-3 package. These compact devices can be used in control circuits, power supplies, Hi-Fi equipment, TVs, Battery Chargers, etc.

The rectifiers are hermetically sealed. Wide ranges of voltages are available. High surge current capability is claimed to be a unique feature.

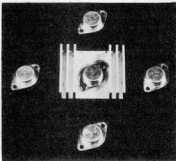

For further information, write to:
Advani-Oerlikon Ltd.
P.O. Box No.1546, Bombay-400 001.

WIRING AIDS

The Novoflex Saddle and Clip wiring system simplifies electrical wiring installation. The system can be fitted without aid of any tools.

It consists of Binders and Clips for unsupported wiring and Saddles with Clips for anchored wiring. These are manufactured in high grade thermoplastic and Polyamide and have high tensile strength. Insulation properties are also good.

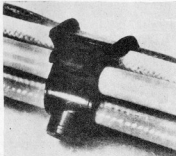

For further information, write to:
Novoflex Cable care Systems,
Post Box No. 9159 Calcutta-700 016.

PRESSFIT CONNECTORS

The G 60 - Reverse Euro pressfit connector is a new addition to the ITT Cannon range. This new design is based on the solderless pressfit technique using contact pins with elastic press-in area. These connectors are easy to mount and their operation is simple. The particular design offers upto 924 polarising possibilities.

These connectors are available against actual users import licence.

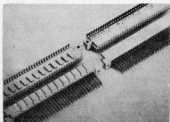

For further information, write to:
Jost's Engineering Company Ltd.
60, Sir Phirozeshah Mehta Road
Fort, Bombay-400 001.

DIGITAL POSITION READOUT

Programmable digital position readout system from Electro-numeric can be used on basic machine tools such as lathe, milling machine, boring machine etc. for measurement readout.

The system is microprocessor based and uses optical glass scale transducers. One inch bright LED display is used for clear view. The position readout can be selected in metric or imperial dimensions through the membrane keyboard on the front panel. Diameter mode or linear mode is also selectable.



For further information, write to:
M/s Electronumerics,
Kammagondanahalli,
Opp. HMT Industrial Estate,
Jalahalli (West) Bangalore-560 015.

DIGITAL MULTIMETER

The OMEGA digital multimeter DMM-012 uses the latest MOS-LSI technology, for measurement of AC/DC Voltage, AC/DC current and resistance. 12.5 mm bright LEDs are used for the display.

It can measure voltages from 0.1 mV to 1000 V (600 V RMS AC), currents in five ranges of 199.9 μ A, 1.999 mA, 19.99 mA, 199.9 mA and 1 Amp. Resistance measurement is possible from 0.1 ohm to 19.99 Meg-ohms in 6 ranges. Range and function selection is through push buttons. Decimal point is automatically selected.



For further information, write to:
OMEGA Electronics,
36, Hathi Babu Ka Bagh
Jaipur-302 006.

New single-board computer is STD bus compatible

Burr-Brown International Limited of Watford, Hertfordshire, have announced a new single-board computer which offers many functions not usually found on similar boards. Known as MP6102, the 280A-based board is designed to operate either in single-processor mode or master/slave mode for multi-processor environments. It may eliminate the requirement for additional serial or parallel I/O cards, counter/timer card, or a separate interrupt controller since these functions are all included on the board. The MP6102 can be used in conjunction with separate RAM cards, also available from Burr-Brown, while 2 K bytes of RAM are provided on the card.

*Burr-Brown International Limited
Cassiobury House
11-19 Station Road
Watford
Herts WD1 1EA
(0923) 33837*

(2984 M)

True reverse style 0.1 inch (2.54 mm) connector

Plessey Connectors has introduced a true reverse style 0.1" pitch printed circuit connector, the Series 20, to meet the growing demand for reliable, cost effective indirect interconnections between printed circuit board and between PCBs and racking frames. The Series 20 connectors, available in 2-row 64-way or 3-row 96-way mouldings, will be supplied with a choice of contact styles for applications in telecommunications, computers, and industrial electronics, including hostile environments. The Series 20 connectors are currently undergoing approval testing to BS9525 F0017 and British Telecom D2580 specifications.

*Plessey Connectors Limited
P O Box 30
Kingsthorpe
Northampton NN2 6NA
(0604) 712000*

(2985 M)

Polisher/grinder

A versatile, lightweight, suspended or bench-mounted polisher/grinder is available from Toolrange Limited. It has been designed for use in small engineering works, or a home workshop, in clock making, jewellery setting and small electronics workshops. The flexible drive is light, very flexible, and bends without strain. The hand piece is of aluminium and has two ballraces to give optimum precision at high speed: it comes complete with a pin



chuck and four steel collets — 0, 1.5 mm, 2.5 mm, and 3.0 mm. The speed is 10 000 rev/min; the supply voltage is 240 VAC and power consumption is 90 W (0.45 A). The unit is supplied with a variable speed foot pedal and a cast base for bench mounting. The polisher/grinder, together with over 3000 other tools and production aids, can be found in the Toolrange 1983/84 catalogue.

*Toolrange Limited
Upton Road
Reading
Berkshire RG3 4JA
(0734) 22245*

(2996 M)

Remotely controlled rotator for aerials or cameras

A substantially built rotatable mounting with remote direction control gets the best out of television, CB, or FM radio aerials, or can be used to mount security cameras. Known as the type 200XL, it is available from Semicon-



ductor Supplies, Sutton, Surrey, by mail order for only £49.45 inclusive. Aerials and camera equipment weighing up to 45 kg (100 lb) can be mounted and rotated by mains power over 365 degrees. Speed of movement is one revolution per 65 seconds. The weatherproof case is made of metal castings.

*Semiconductor Supplies International Limited
Dawson House
128/130 Carshalton Road
Sutton
Surrey SM1 4RS
(01 643) 1126*

(2983 M)

Single-chip teletext decoder controls up to eight pages

The new TPU2700 from ITT Semiconductors provides a single-chip solution to teletext, and offers improved performance with the capability of acquiring and storing eight pages simultaneously. It decodes the standard Level 1 teletext transmissions widely used in the UK and other European countries, and interfaces direct to the digital-signal-processing Digit-2000 IC family. Up to eight

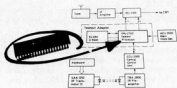

stored pages are controlled by the processor, giving a much reduced access time over current multi-chip decoder designs. A menu of the stored pages is also available to the user. The only external components necessary to build a decoder is some RAM in the form of a 64K x 1 device, or a number of 16K parts. It can serve in receivers for eight different language teletext transmissions, either on PAL or NTSC standards. The TPU2700 comes in a 40-pin plastic DIL case, and requires a single 5 V supply; consumption is typically 1.25 W.

*ITT Semiconductors ITT Semiconductors
145-147 Ewell Road 500 Broadway
Surbiton Lawrence
Surrey KT6 6AW Massachusetts 01841
England USA
(01 390) 6578/79 617 688 1881*

(2995 M)

'Slopefront' LCD multimeter

A new low-cost LCD multimeter, type DP2020 has been announced by Lascar Electronics. A unique feature is the angled display which makes the instrument very easy to use either hand-held or laid on a bench. The case is moulded in ABS, making the DP2020 suitable for use in the laboratory or field use. Six func-

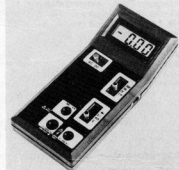

tions are available: DC volts, AC volts, DC amps, AC amps, resistance, and diode check — a total of 21 measurement ranges. Protection against accidental overload is built in. The instrument can work up to 2000 hours from a standard PP3 battery. It is available from stock at £ 24.95 + VAT.

*Lascar Electronics Limited
Module House
Whiteparish
Salisbury
Wiltshire SP5 2SJ
(07 948) 567*

(2997 M)

New portable mains filter LF 134

New from Roxburgh Suppressors Limited is a multi-outlet portable mains filter Type LF 134. Rated at 13 A, the unit provides four 13 A sockets and is constructed in a steel case fitted with a neon mains indicator. The LF 134 has two metres of mains lead and is complete with a 13 A plug for immediate use. The device provides a high degree of protection from mains transients and interference for analogue and digital instruments, and microcomputer systems and their peripherals. Maximum pro-

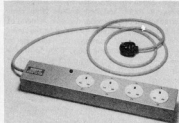

tection is obtained by the incorporation of a high performance mains filter with a varistor transient clipper. Dimensions are 425 x 78 x 45 mm, and the unit weighs 1.5 kg. Unit price is £54.34 excluding VAT, carriage and packing.

Roxburgh Suppressors Ltd.
Haywood Way
Ivyhouse Lane
Hastings
East Sussex TN35 4PL
(0424) 442 160

(3008 M)

DC solid-state relay

International Rectifier has introduced a new range of solid-state relays, the Crydom Series 1-DC, which use a HEXFET (the trademark for International Rectifier power MOSFETs) output stage to offer d.c. switching at up to 40 A. The input of these relays can be driven from most logic circuits and requires less than 1.6 mA at 5 V d.c.

International Rectifier
Hurst Green
Oxted
Surrey RH8 9BB
(088 33) 3215/4231

(2986 M)

Programmable, single-chip video generator

Plessey Semiconductors has released for production a single-chip video generator, MR9735, with an on-board character set which the company claims can be programmed in virtually any language. The MR9735 can replace up to three ICs in currently available Prestel/Teletext chip sets. The MR9735 is designed to meet the new CEPT specifications for Prestel and Teletext.

Plessey Semiconductors Limited
Cheney Manor
Swindon SN2 2WQ
(0793) 36251

(2987 M)

True r.m.s. voltmeter measures complex waveforms

The Type 22610 portable voltmeter from Marconi Instruments, which provides true r.m.s. voltage measurements on waveforms of any complexity, can now be hired from Microlease PLC. The instrument offers a bandwidth from 5 Hz to 25 MHz and measures voltages from 2 mV to 700 V on seven ranges and handles signals with crest factors as high as 7:1, allowing waveforms of virtually any complexity to be applied to its high impedance input. Coupling between the input and thermal conversion measurement circuit may be a.c. or d.c., allowing measurement of asymmetric signals, signals with a d.c. component, or pure d.c. fundamental measurement period is around 40 ms, providing a reading rate of 225/s, but lower rates down to 0.2/s may be specified. The instrument may be used in autorangeing or



manual mode. Decibel measurements are also provided. Readings are presented on an LCD display, along with an analogue meter for convenience when making peak measurements. The voltmeter can be hired from Microlease for periods of a week upwards; the weekly hire rate is from £38.50.

Microlease PLC
Forbes House
Whitefriars Estate
Tudor Road
Harrow
Middlesex HA3 5SS
(01 427) 8822

(3009 M)

Dot Matrix Evaluation System

A Dot Matrix Evaluation System now available from Lascar Electronics is claimed to save hundreds of man-hours and thousands of pounds in development costs. It allows use of Dot Matrix Displays by users without specialised microprocessor knowledge.

The system is available at a special offer price of £49.95 (+ p&p and VAT) and comprises a

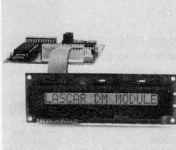

16-character line display complete with bezel and panel mounting kit, a microprocessor based controller module, inter-connecting cable and a full instruction manual. A 5 V d.c. supply is all that is required to have an LCD DOT Matrix Display system up and running in minutes.

The controller module contains a pre-programmed EPROM which contains the initialisation programme plus 15 standard 'messages'. On-board hexadecimal and programme switches allow custom messages and programmes to be developed. These can then be saved, either by implementing a 'power down' mode or by reprogramming the EPROM.

Expansion of the system is easily attained as all controls, data lines etc. are brought out to a 32 way double-sided edge connector.

The programme messages can also be switched to the display by contact closure or open collector transistor output.

The EVAL-1 Evaluation System will allow many potential new users of Dot Matrix Displays to fit them to their instruments in the minimum time and cost.

Lascar Electronics Limited
Module House
Whitmarsh
Salisbury
Wiltshire SP5 2SJ
(07 948) 567

(3006 M)

Holders for direct PCB mounting of zinc-air batteries

Gould Micro Power Systems has introduced a new range of plastic battery holders which allow the company's range of zinc-air button cells to be mounted direct onto printed-circuit boards. The new holders, which cover all the standard sizes and ratings of zinc-air cells, will enable the exploitation of the energy-density benefits of zinc-air cells in memory-back-up or

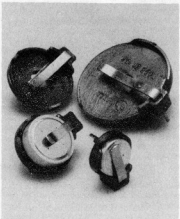

portable equipment applications. Typically, the Type 630 EL zinc-air cell offers 950 mAh with a maximum drain rate of 42 μ A. The new holders are produced in a heat-stable material with a low-profile design and spacer feet allowing air flow.

Gould Micro Power Products Division
11 Ash Road
Wrexham Industrial Estate
Wrexham
Chwyd LL13 9UF
(0878) 61984

(3007 M)

When India is waking up to make
some of the finest
colour TVs in the world...

There's only one capacitor
to say "Good morning"...

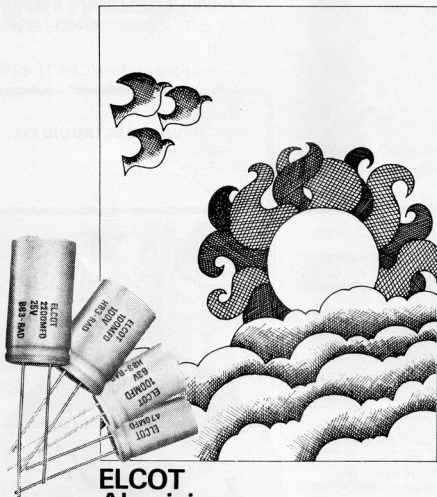

ELCOT
Aluminium
Electrolytic Capacitors

Signalling the dawn of a new era in component electronics, ELCOT introduces Aluminium Electrolytic Capacitors—with Tolerance ranging from -10% to +20%, and operating temperature ranging from -40°C to 85°C. ELCOT Electrolytic Capacitors are made with the most modern technology on the latest high-speed Japanese machines. That is why they have the unmatched characteristics of perfection, and can be used in both Colour and Black & White TVs. Also in hi-fi sets, walkie-talkies, personal computers and other consumer and industrial electronic items. And watch out for the ELCOT Bipolar and 'S' Correction Capacitors, soon to be on the market!

ELCOT

**Electronics Corporation of
Tamil Nadu Ltd.**
(A Govt. of Tamil Nadu Enterprise)
LLA Buildings, 735, Anna Salai
Madras 600 002
Ph: 810771, 87659, 83776
Telex: 041-6113 LCOT IN

ELCOT - Shaping the future of electronics

©IPR/211/84

CONDITIONS OF ACCEPTANCE OF CLASSIFIED ADVERTISEMENTS

1) Advertisements are accepted subject to the conditions appearing on our current rate card and on the express understanding that the Advertiser warrants that the advertisement does not contravene any trade act in force in the country.

2) The Publishers reserve the right to refuse or withdraw any advertisement.

3) Although every care is taken, the Publishers shall not be liable for clerical or printer's errors or their consequences.

4) The Advertiser's full name and address must accompany each advertisement submitted.

The prepaid rate for classified advertisement is Rs. 2.00 per word (minimum 24 words). Semi Display panels of 3 cms by 1 column. Rs. 150.00 per panel. All cheques, money orders, etc. to be made payable to Elektor Electronics Pvt. Ltd. Advertisements, together with remittance, should be sent to The Classified Advertisement Manager. For outstation cheques please add Rs. 2.50

Electronics Tools like Soldering Irons, Pliers, Cutters, Screw Drivers, Tweezers at Competitive Prices. Contact Aradhna Electronics (P) Ltd., 10, Srinath Complex, Sarojinidevi Road, Secunderabad 500 003.

ANIL ENGINEERING WORKS	10.64
APLAB	10.13
ARPHI ELECTRONICS (P) LTD.	10.12
BALAJI	10.68
COMPONENT TECHNIQUE	10.69
COSMIC	10.76
DEVICE ELECTRONICS	10.71
DOMINION RADIOS	10.06
DYNALOG	10.11
ELCOM	10.69
ELCOT	10.63
GRAFICA DISPLAY CO.	10.72
IEAP	10.12
INTERTEC	10.07
ION ELECTRICALS	10.64
INDUSTRIAL RADIO HOUSE	10.08
INSTRUMENT CONTR. DEVICES	10.06
LUXCO	10.65
MFR	10.71
NATIONAL INDUSTRIES	10.69
OSWAL	10.64
PADMA ELECTRONICS	10.08
PHILIPS	10.05
PLA	10.09
RUTONSHA	10.12
SCIENTIFIC	10.06
VISHA	10.75
ZODIAC	10.08

missing link

capacitance meter

(March 1984, page 3-42)

Some unfortunate errors crept into the above article. The first two paragraphs under 'construction' should read:

First of all, mount and solder all components except C10 and R12, where pins should be fitted. Next, fit all components (but wire links instead of resistors R1 and R7) to the display board shown in figure 7. The display and LEDs must be located on the track side; the LEDs should be soldered as close to the board as possible to ensure that they are flush with the display. Lastly, fit wire bridge B.

Additionally:

■ Note that neither wire bridge A nor input Z shown in figure 5 is used.

■ It is advisable to fit C15 and IC8 on the track side of the metering board to ensure that the switch shaft of the range selector projects from the front panel on final assembly.

■ It is recommended that a type 1N4148 diode be connected in series with each of the LEDs D4...D7 to prevent possible malfunctioning of ES1...ES3 through leakage currents of the LEDs.

■ It happens from time to time that when a capacitor is measured with S1 set to too high a range the display indicates odd values. This may be prevented by soldering a 100 ohm resistor between pin 6 of IC2 and the +Cx terminal.

■ R1, R7, D1, and D3 are not used and should therefore be deleted from the relevant circuit diagram and parts list.

daisywheel typewriter printer interface

(July 1984, page 7 - 32)

There is an error in Table 2 of this article. The 'Y2(0AHex)' should read 'Y5(10AHex)'.

universal active filter

(February 1984, page 2-36)

In the circuit diagram of figure 1 we have somehow managed to confuse a number of pins in IC5. Pins 4, 5 and 6 should be connected to the +10 V line whereas pins 8, 9 and 12 should be connected to ground.

frequency meter

(August/September 1984, page 8 - 38)

The circuit diagram on page 7-44 indicates IC4 as 4515. This should, in fact, be 4518, as the parts list correctly states.

maximum and minimum memory

(July 1984, page 7 - 37)

Offset tolerances in the op-amps used can result in the memory range of 0 to 1 volt not operating correctly. This is noticed when the input is 0 V as the output voltage in the minimum position drops from 1 V (after a reset, for example) to almost 0 V and then jumps to 1 V only to fall towards 0 V again, and so it goes on. Just the opposite happens for the 'maximum' voltage.

The cure for this condition is to provide an offset correction for A5 by connecting a 25 k preset between pins 1 and 5 with the wiper to +5V.

CAPACITORS

ELECTROLYTIC RADIAL TYPE

Values in μf

63V—1, 2.2, 3.3, 4.7, 6.8, —0.90
25V—10, 15, 22, —0.90
25V—47—1.00, 100—1.35, 220—2.50, 330—2.50, 470—3.25, 1000—4.50
16V—2200—5.15

ELECTROLYTIC AXIAL TYPE

Values in μf

16V—10, 22, 33, 47—1.50, 100—1.85, 220—2.25, 330—2.85, 470—4.75, 1000—5.95
25V—47—1.50, 100—1.95, 220—3.25, 470—4.75, 1000—6.50
50V—1000—10.50, 2200—18.00
25V—2200—10.50, 4700—18.00

CERAMIC DISC—50V

1 μf to 10 μf —0.80

METALISED POLYESTER—250V

Values in μf

0.1—1.50, 0.15—2.00, 0.22—2.50

POLYESTER—100V

Values in μf

10—1.50, 22—1.50, 33—1.50, 47—1.50, 68—1.50

PRESET

MR Horizontal—2.00

MR Vertical—1.50

RESISTORS

Range ohms each value per 100

1/4 W	10—1M	10.00
1/2 W	10—1M	18.00
1 W	10—1M	30.00
2 W	10—1M	55.00

Reed Switch—Rs. 5.00

Reed Relay—NO 5V, 12V—Rs. 20.00

3 1/2 digit DPM kit
without power supply
(LCD Version) Rs. 350.00



We stock parts to build
MUSICAL PROJECTS

SEMICONDUCTORS

741	6.00
555	7.00
741 T05	14.00
723 DIL	12.00
723 T05	16.00
BEL 700	12.00
7400	7.00
7402	7.00
7492	18.00
7413	12.00
7447	20.00
7490	15.00
7493	15.00
LM 308	18.00
LM 380	15.00
LM 381	35.00
LM 382	30.00
LM 301	10.00
LM 324	12.00
LM 339	12.00
LM 377	45.00
LM 386	20.00
LM 390	35.00
LM 710	16.00
LM 1458	10.00
LM 1818	85.00
LM 379 S	85.00
LM 3900	10.00
LM 3914	65.00
LM 3915	65.00
MM 5387	50.00
JAA 170	35.00
JAA 180	45.00

TRANSISTORS

2SA 564	12.00
2SA 634	10.00
2SA 671	16.00
2SA 715	10.00
12SA 733	6.00
2SA 1015	12.00
2SA 1102	60.00
2SB 536	20.00
2SB 544	12.00
2SC 536	6.00
2SC 828	2.50
2SC 929	4.00
2SC 1096	10.00
2SC 1162	10.00
2SC 1383	8.00
2SC 1507	20.00
2SC 1684	5.00
2SD 200	30.00
2SD 201	30.00
2SD 202	30.00
2SD 261	16.00
2SD 288	15.00
2SD 381	20.00
2SD 382	20.00
2SD 400	8.00
2SD 526	15.00
BU 208	22.00
FET K49	10.00
MOSFET BF960	20.00
2 N 5401	20.00
FET BF 256A	25.00

IN STOCK

PCB and parts for 12 tuning musical door bell from Elektor J 16/17 for just Rs. 105.00 (with Jinet)

Special Kits For:

- Stereo Amplifier 6+6 W using TDA 2004
- LED Digital Clock with calendar function (month/date), using 7317 B Digit size —31/2, 1/2 inch. (cabinets also supplied for digital clock)

Analog Multimeters

Sanwa P3	Rs. 210.00
Sanwa YX360TR	Rs. 400.00
HM 101 mini	Rs. 225.00

See our advertisement in next issue for
Computer Peripherals
For ZX 81, ZX Spectrum, BBC Micro, Apple etc.

available
PCBs for most elektor projects

TERMS :

- Goods by return subject to availability.
- Special prices for Volume order.
- Minimum outstation orders Rs. 50/-
- All orders must carry a minimum advance of 50%, balance payment through VPP or by Bank. (No cheque payment).
- Prices are subject to change without any prior notice will be charged as prevailing on date of despatch of goods.
- All prices are exclusive of M. S. T.

VISHA
ELECTRONICS

PHONE US TO CHECK AVAILABILITIES
OF COMPONENTS

Faithful reproduction One good reason is enough

COSMIC

STEREO CASSETTE TAPE DECKS
STEREO CASSETTE TAPE RECORDERS
STEREO TURNTABLES.



CO-8500 D STEREO CASSETTE TAPE DECK

Frequency Response: 30-12000 Hz (LN tape), 30-16000 Hz (CrO₂ tape). **Signal to Noise Ratio:** Better than -45dB. **Wow & Flutter:** Less than 0.2% WRMS. **Heads (2):** One High Density Super Permalloy REC/PB. One Erase.

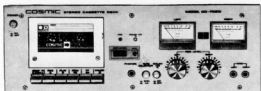

CO-703 D STEREO CASSETTE TAPE DECK

Frequency Response: 30-13000 Hz \pm 3dB (LN tape), 30-16000 Hz \pm 3dB (CrO₂). **Signal to Noise Ratio:** Better than -54dB (LN tape), Better than -56dB (CrO₂ tape). **NR Dolby Switch ON:** Improves upto 10 dB above 5 KHz. **Wow & Flutter:** Less than 0.06% WRMS. **Heads (2):** One Glass Surface Ferrite REC/PB. One Erase.



CO-360 STEREO CASSETTE TAPE RECORDER WITH BUILT-IN AMPLIFIER

Frequency Response: 30-12000 Hz (LN tape), 30-16000 Hz (CrO₂ tape). **Signal to Noise Ratio:** Better than -40dB. **Wow & Flutter:** Less than 0.2% WRMS. **Heads (2):** One High Density Super Hard Permalloy REC/PB. One Erase.



CO-5100 D STEREO CASSETTE TAPE DECK

Frequency Response: 30-13000 Hz \pm 3dB (LN tape), 30-16000 Hz \pm 3dB (CrO₂ tape). **Signal to Noise Ratio:** Better than 60dB (JIS A) (LN tape), Better than 63dB (CrO₂ tape). **NR Dolby Switch ON:** Improves upto 10 dB above 5 KHz. **Wow & Flutter:** Less than 0.06% WRMS. **Heads (2):** One High Density Super Hard Permalloy REC/PB. One double gap erase.



HS 410 DD DIRECT DRIVE STEREO TURNTABLE

Platter: 30cms. diameter with Built-in Stroboscope for 50 Hz and 60Hz. **Motor:** Servo controlled - Direct Drive. **Wow & Flutter:** Below 0.04% RMS JIS. C5521. **Cartridge:** Magnetic with diamond stylus.



STUDIO STANDARD SERIES K8 STEREO CASSETTE TAPE DECK

Frequency Response: Metal tape -20Hz to 20KHz (30Hz to 17 KHz \pm 3dB), CrO₂ tape -20Hz to 18KHz (30Hz to 16KHz \pm 3dB), LH tape -20Hz to 15 KHz (30Hz to 15 KHz \pm 3dB). **Signal to Noise Ratio:** Metal Tape - better than -58dB (NR OFF); better than -65dB (NR ON), (CrO₂ tape - better than -57dB (NR OFF); better than -63dB (NR ON), LH tape - better than -55dB (NR OFF); better than -60dB (NR ON). **Wow & Flutter:** Less than 0.055% WRMS. **Heads (2):** One Sendust REC/PB. One double gap erase.



CO-GRAM 4000 DD MK II DIRECT DRIVE STEREO TURNTABLE

Platter: 30cms. diameter with Built-in Stroboscope. **Motor:** Servo Controlled - Direct Drive. **Wow & Flutter:** Below 0.07% RMS JIS C5521. **Cartridge:** Magnetic, with diamond stylus.



CO-GRAM 2000 BD BELT DRIVE STEREO TURNTABLE

Platter: 28cms. diameter, Aluminium alloy die-cast. **Motor:** 4 pole synchronous motor - Belt Drive. **Wow & Flutter:** 0.15% WRMS. **Cartridge:** Magnetic, with diamond stylus.

International quality created for India by **COSMIC**